

Model # B10RCP

# HARDWARE

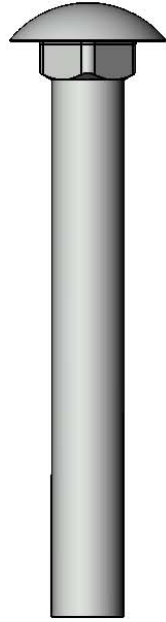

5/16" x 1"  
Machine Bolt



3/8" x 3"  
Carriage Bolt

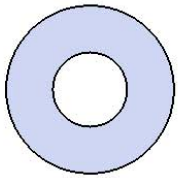

5/16" Washer

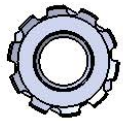

5/16" Washer

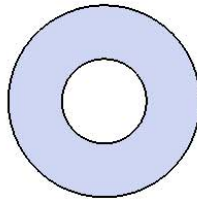

3/8" Washer

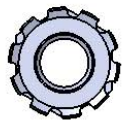

3/8" Washer

# PRODUCT SPECIFICATIONS

## **B10RCP PORTABLE BENCH WITHOUT BACK**

Seat & Back: 2" x 2" x 1/8" formed angle frame with 1-1/2" radius corners. 3/4" #9 steel expanded metal. 7 gauge x 1-1/2" flat bar center support and mounting bracket understructure. Electrically MIG welded.

Coating: Oven fused functionalized polyethylene copolymer-based thermoplastic. Fluidized bed coating application with superior mechanical performance, impact resistance and UV-stability.

Frame: 2-3/8" O.D. x 12 gauge pre-galvanized structural steel tubing. Tube ends are pre-galvanized steel capped. Seat mounting points are 7 gauge x 1-1/2" die stamped steel flat bar. Cross braces are 1" O.D. x 16 gauge pre-galvanized structural steel tubing. All electrically MIG welded.

Frame Coating: Electrostatic powder coated application oven cured.

Hardware: All stainless steel hardware fasteners.

Dimensions: 10' portable bench without back. Seat is 10" wide x 120-1/4" long x 18-1/2" high. Overall dimensions are 22-1/4" x 18-1/2" x 120-1/4".

# COMPONENTS

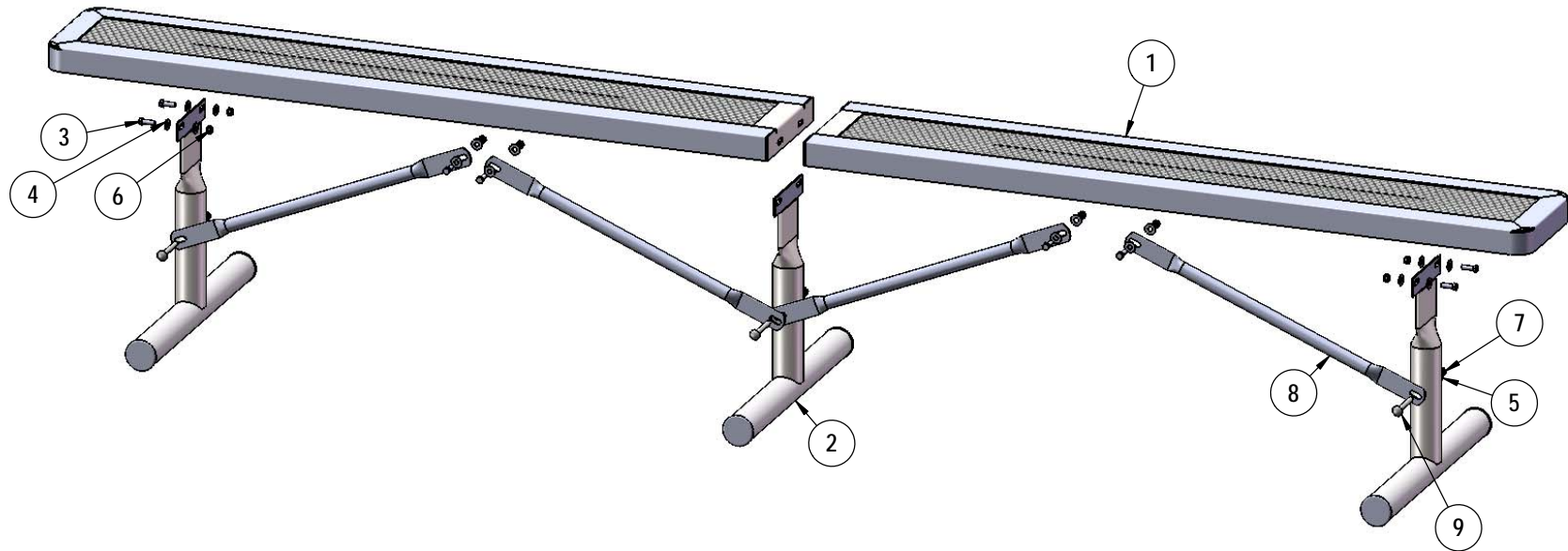

ITEM NO.	PartNo	DESCRIPTION	QTY
1	RC60-S	5' x 10" wide regal expanded seat (1/2)	2
2	P-V942P	942P Vinyl Leg	3
3	33-05-0029	5/16" x 1" Machine Bolt (SS)	10
4	33-02-0007	5/16" SS Washer	20
5	33-02-0008	3/8" Flat Washer (SS)	3
6	33-03-0012	5/16" Keps Nut (SS)	10
7	33-03-0013	3/8" Keps Nut (SS)	3
8	P-01-04-0129	26 3/4" Brace	4
9	33-06-0058	3/8" x 3" Carriage Bolt (SS)	3

**Superior**<sup>®</sup>  
 RECREATIONAL PRODUCTS  
A PLAYCORE Company

# STEP 1

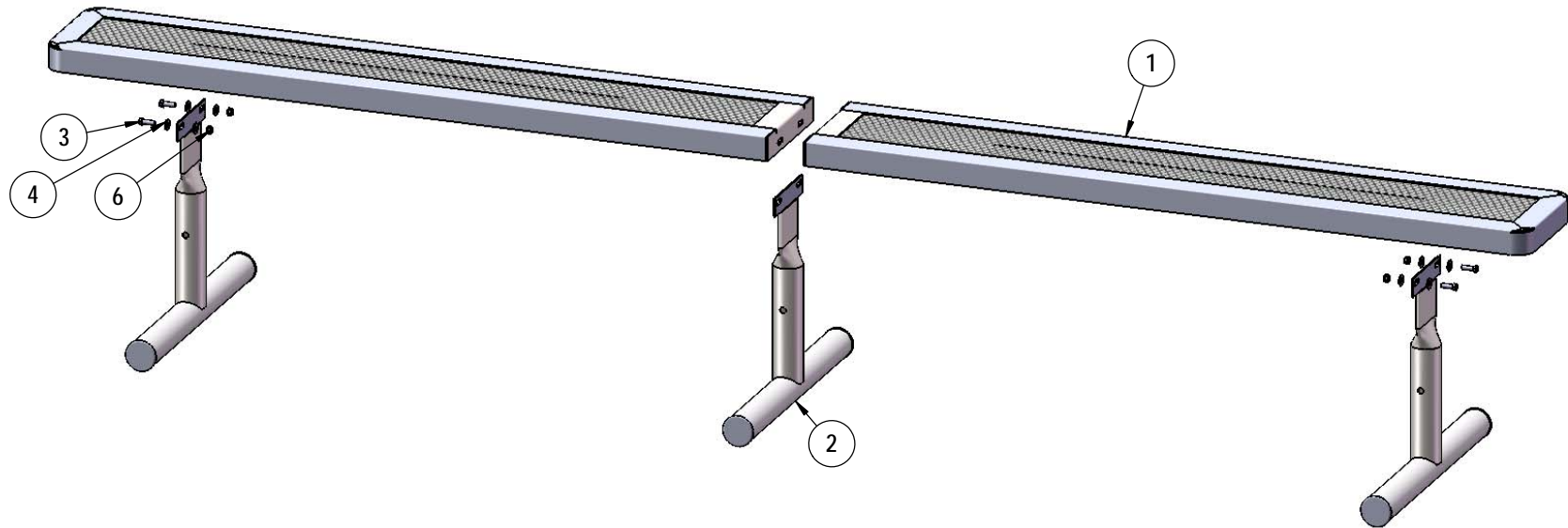

Attach the seat planks to the legs as shown using specified hardware.

## STEP 2

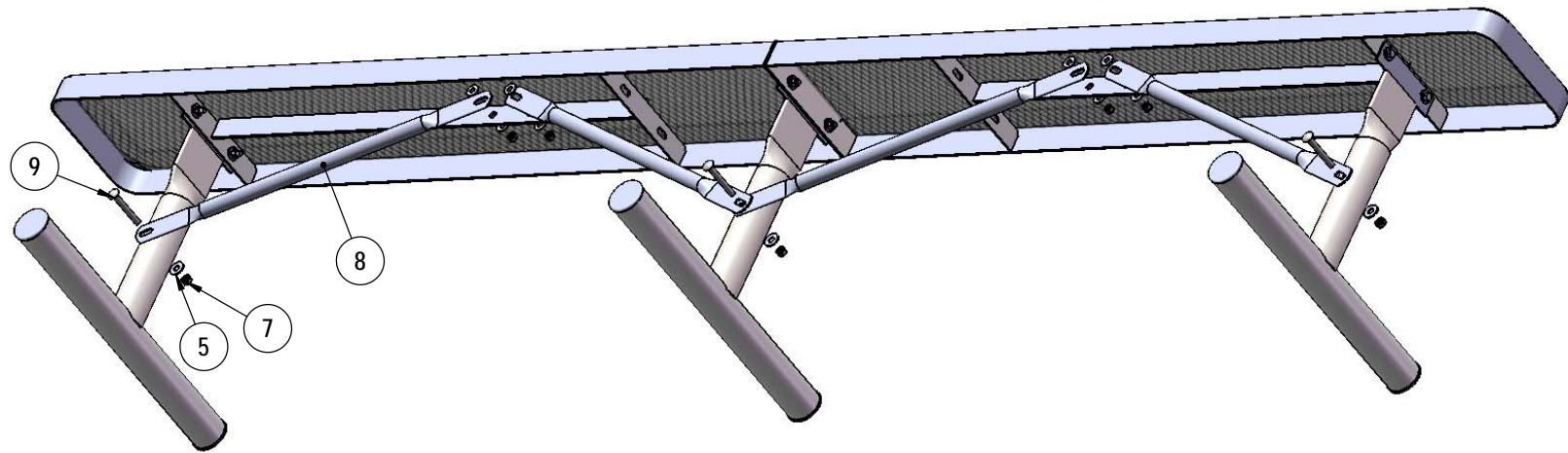

Attach the braces to the legs as shown using specified hardware.

# OVERALL DIMENSIONS

