

Model # B10RCS

# HARDWARE

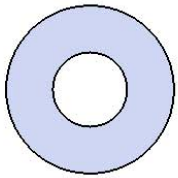

5/16" x 1"  
Machine Bolt



5/16" Washer

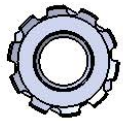

5/16" Washer

# PRODUCT SPECIFICATIONS

## **B10RCS INGROUND BENCH WITHOUT BACK**

Seat & Back: 2" x 2" x 1/8" formed angle frame with 1-1/2" radius corners. 3/4" #9 steel expanded metal. 7 gauge x 1-1/2" flat bar center support and mounting bracket understructure. Electrically MIG welded.

Coating: Oven fused functionalized polyethylene copolymer-based thermoplastic. Fluidized bed coating application with superior mechanical performance, impact resistance and UV-stability.

Frame: 2-3/8" O.D. x 12 gauge pre-galvanized structural steel tubing. Tube ends are pre-galvanized steel capped. Seat mounting points are 7 gauge x 1-1/2" die stamped steel flat bar. All electrically MIG welded.

Frame Coating: Electrostatic powder coated application oven cured.

Hardware: All stainless steel hardware fasteners.

Dimensions: 10' inground bench without back. Seat is 10" wide x 120-1/4" long x 18" high.

# COMPONENTS

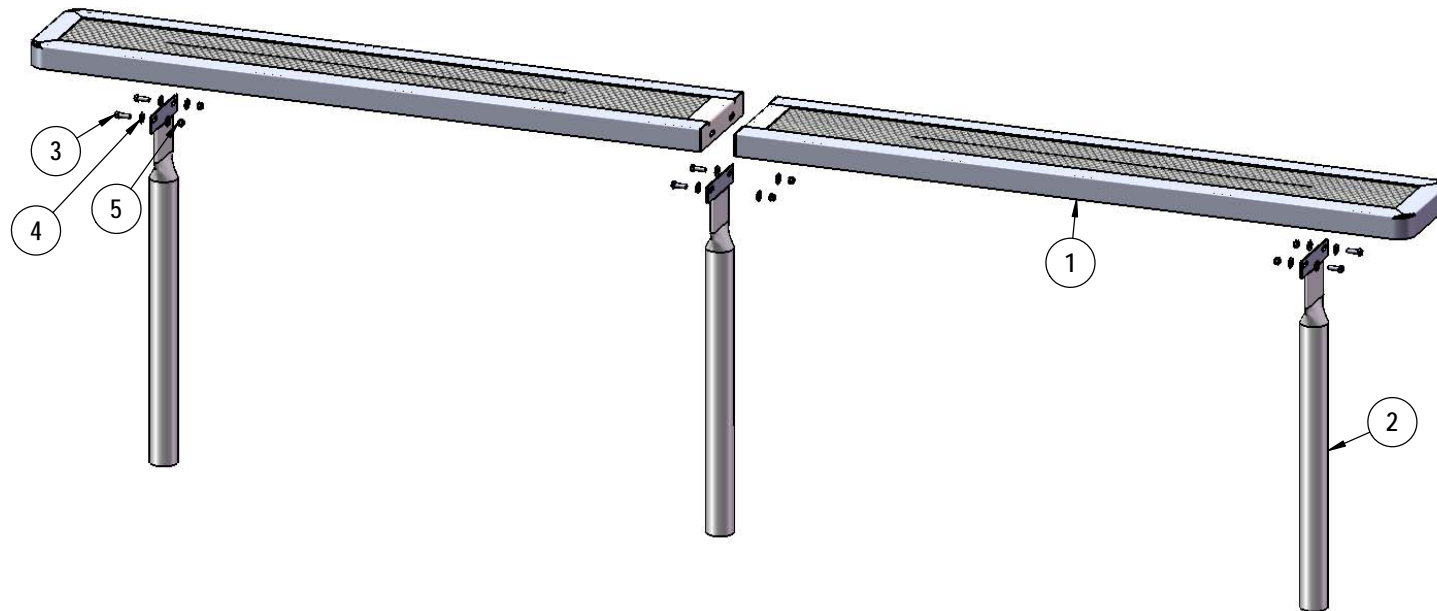

Attach the seat planks to the legs as shown using specified hardware.

ITEM NO.	PartNo	DESCRIPTION	QTY
1	RC60-S	5' x 10" wide regal expanded seat (1/2)	2
2	P-V942S	942S VINYL LEG	3
3	33-05-0029	5/16" x 1" Machine Bolt (SS)	6
4	33-02-0007	5/16" SS Washer	12
5	33-03-0012	5/16" Kep Nut (SS)	6

# FOOTINGS

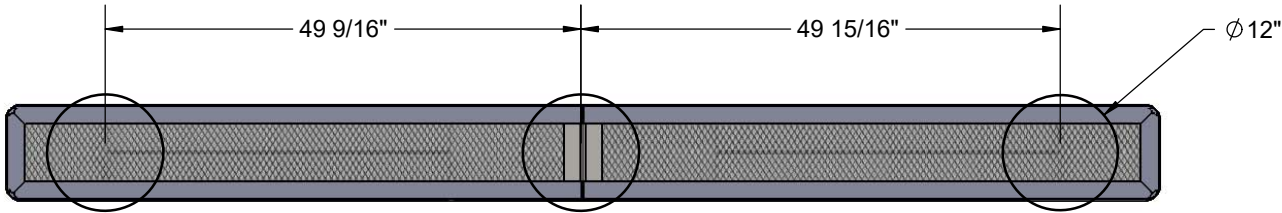

Estimated Required Concrete:  
11 - 50 lb Bags of Concrete

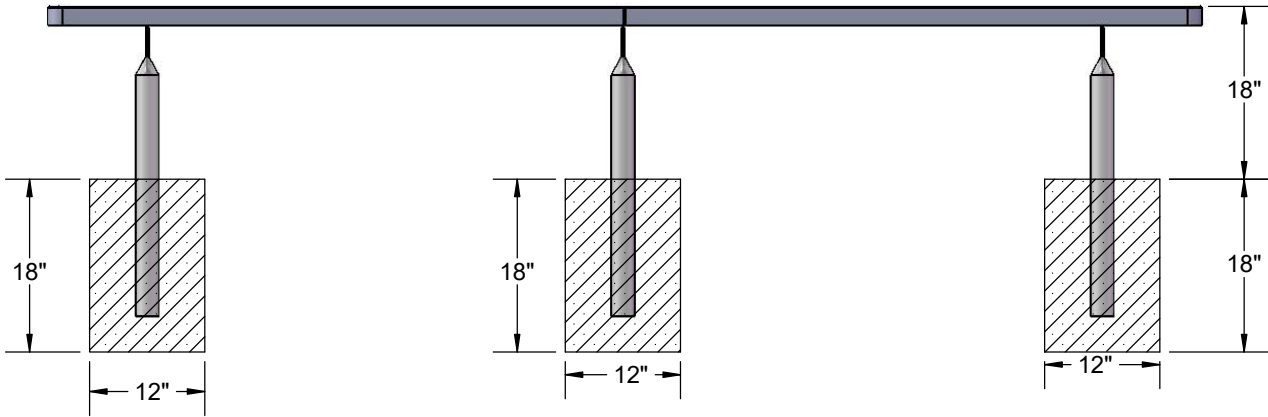

# OVERALL DIMENSIONS

