

# Site Amenities

BY SUPERIOR RECREATIONAL PRODUCTS

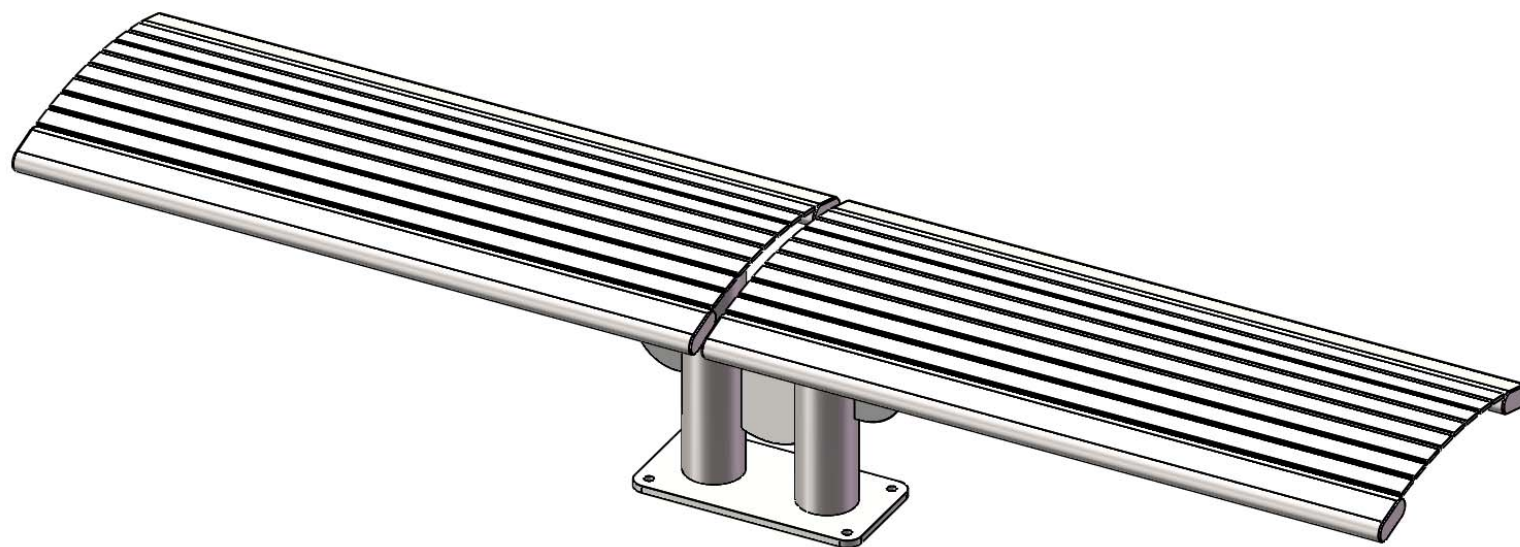

Model # B4ARSM-ST-CANT

# HARDWARE

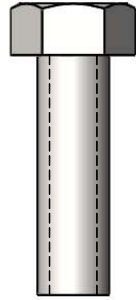

3/8" x 1-1/4"  
MACHINE BOLT

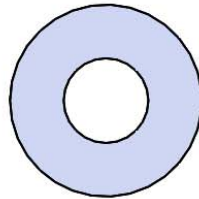

3/8" FLAT  
WASHER

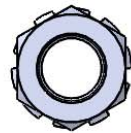

3/8" KEPNUT

# ULTRA SITE PRODUCT SPECIFICATIONS

## **68SM-HS4 DOUBLE CANTILEVER SURFACE MOUNT BENCH**

**Seat:** The seats are fabricated from 1 ½" x ¼" flat steel strips. Reinforced with ¼" thick support ribs. End Planks are made from 1-1/2" x 3-1/2" steel oval tubing.

**Frame:** 4" diameter x 11 gauge structural steel tubing. Attachment plates are ¼" thick flat steel. Surface Mount (SM) plates are made from ½" thick flat steel. All electrically MIG welded.

**Coating:** Steel is sandblasted to near white condition. Coated with zinc rich epoxy primer and top coated with electrostatic powder coat, oven cured.

**Dimensions:** double 4' surface mounted bench without back. Seats are 20" wide x 48" long. Seat height is 17-5/8" from the ground to the top of the seat. The overall dimensions are 96-3/4" x 20" x 17-5/8"

# COMPONENTS

Attach the 4' seats to the 68 Bench Leg using specified hardware.

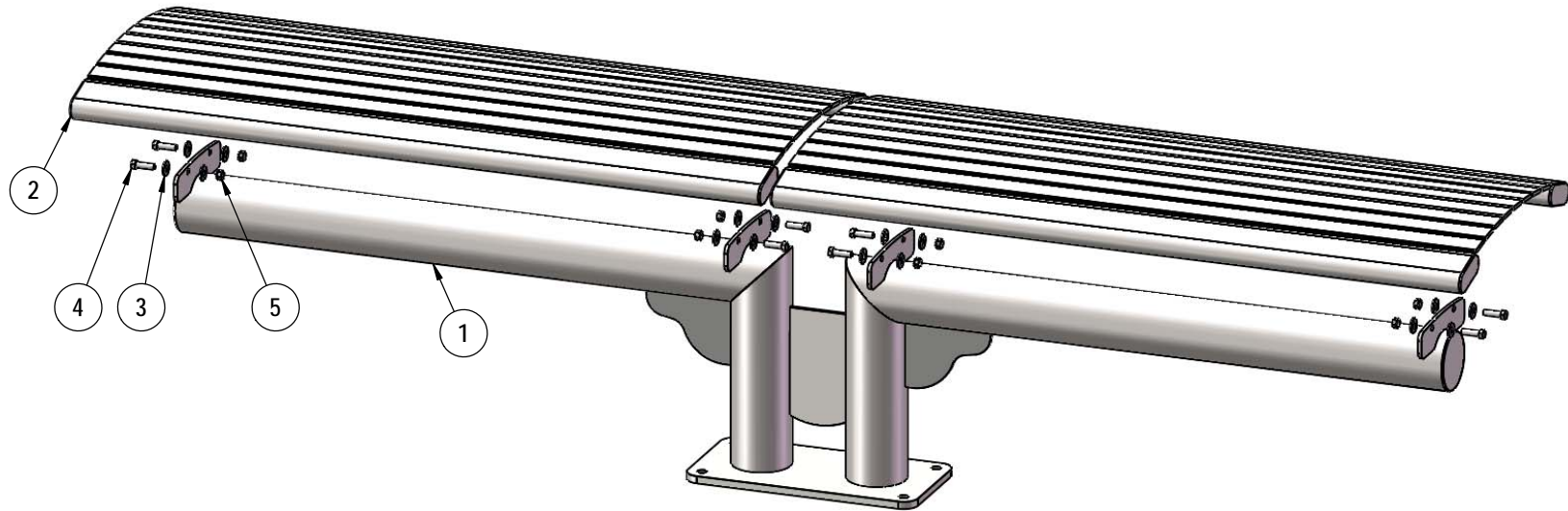

ITEM NO.	PartNo	DESCRIPTION	Qty.
1	01-01-0892	68 Bench Leg - SM	1
2	01-01-0897	4' horizontal slat seat assembly	2
3	33-02-0008	3/8" Flat Washer (SS)	16
4	33-05-0078	3/8" x 1 1/4" Machine Bolt (SS)	8
5	33-03-0013	3/8" Kep Nut (SS)	8

Recommended Surface Mount Hardware: 1/2" x 3-1/2" Concrete Expansion Anchor Bolts (Not Included)

# OVERALL DIMENSIONS

