

Model # B6WBRCM-ELEM

# HARDWARE

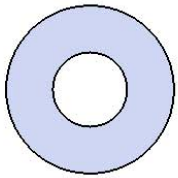

5/16" x 1"  
Machine Bolt



5/16" Washer



5/16" Kep Nut

# PRODUCT SPECIFICATIONS

## **B6WBRCSM-ELEM PRE-SCHOOL SURFACE MOUNT BENCH WITH BACK**

Seat & Back: 2" x 2" x 1/8" formed angle frame with 1-1/2" radius corners. 3/4" #9 steel expanded metal. 7 gauge x 1-1/2" flat bar center support and mounting bracket understructure. Electrically MIG welded.

Coating: Oven fused functionalized polyethylene copolymer-based thermoplastic. Fluidized bed coating application with superior mechanical performance, impact resistance and UV-stability.

Frame: 2-3/8" O.D. x 12 gauge pre-galvanized structural steel tubing. Tube ends are pre-galvanized steel capped. Seat mounting points are 7 gauge x 1-1/2" die stamped steel flat bar. A 6" x 6" steel plate makes up the surface mount footing. The surface mount plate has four holes for stable mounting, and clipped corners for a more finished look. All electrically MIG welded.

Frame Coating: Electrostatic powder coated application oven cured.

Hardware: All stainless steel hardware fasteners.

Dimensions: 6' pre-school surface mount bench with back. Seat is 10" wide x 72" long x 14-1/2" high. Overall dimensions are 21-9/16" x 30-3/8" x 72".

# COMPONENTS

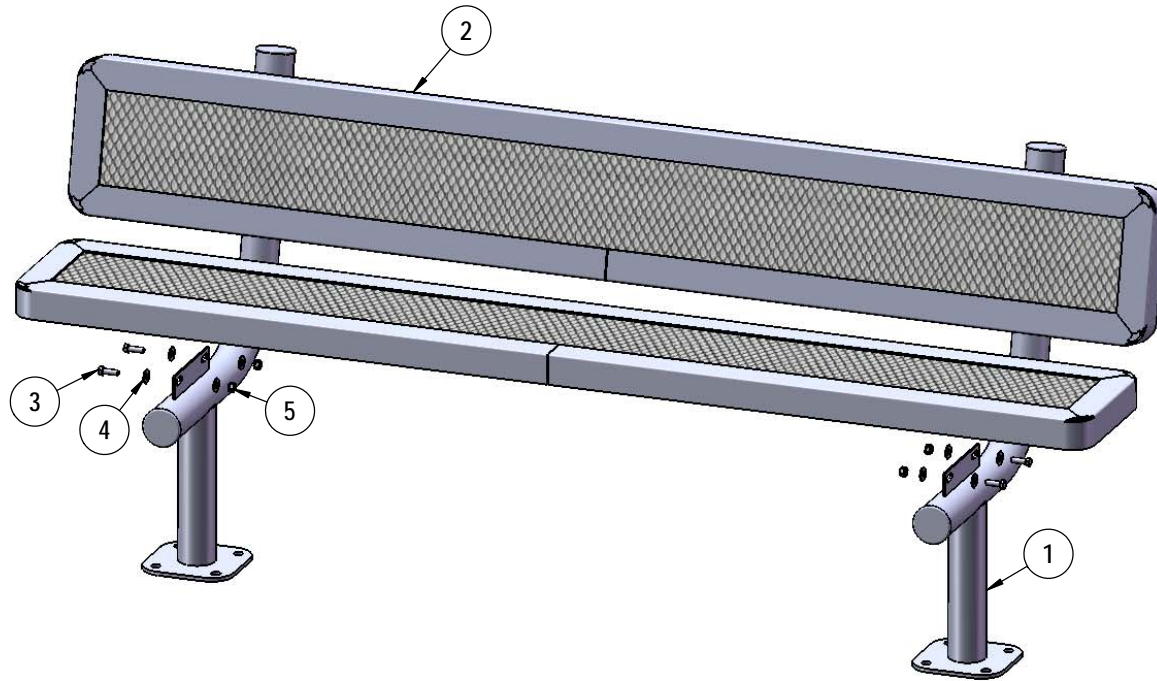

Attach the seat planks to the legs as shown using specified hardware.

Required Surface Mount Hardware:  
 3/8" x 3-1/2" Concrete Expansion Anchor Bolts  
 (Not Included)

ITEM NO.	PartNo	DESCRIPTION	QTY
1	01-01-1122	940 SM Leg 14-1/4" seat height	2
2	RC72-S	6' long x 10" wide regal expanded seat	2
3	33-05-0029	5/16" x 1" Machine Bolt (SS)	8
4	33-02-0007	5/16" SS Washer	16
5	33-03-0012	5/16" Kep Nut (SS)	8

**Superior**<sup>®</sup>  
 RECREATIONAL PRODUCTS  
A PLAYCORE Company

# OVERALL DIMENSIONS

