

Model # B8WBRCD4-4S

HARDWARE

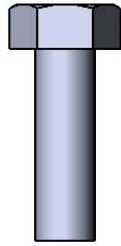

5/16" x 1"
Machine Bolt

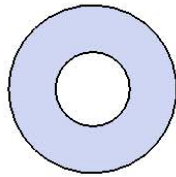

5/16" Washer

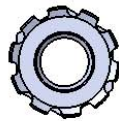

5/16" Washer

PRODUCT SPECIFICATIONS

B8WBRC4-4S DOUBLE SIDED INGROUND BENCH WITH BACK

Seat & Back: 2" x 2" x 1/8" formed angle frame with 1-1/2" radius corners. 3/4" #9 steel expanded metal. 7 gauge x 1-1/2" flat bar center support and mounting bracket understructure. Electrically MIG welded.

Coating: Oven fused functionalized polyethylene copolymer-based thermoplastic. Fluidized bed coating application with superior mechanical performance, impact resistance and UV-stability.

Frame: The main post is fabricated from 4 x 4 x 11 gauge square tubing. 2-3/8" O.D. x 12 gauge pre-galvanized structural steel tubing seat support. Seat arms are supported by a 1/4" thick, 6" gusset. Tube ends are pre-galvanized steel capped. Seat and back mounting points are 7 gauge x 1-1/2" die stamped steel flat bar. All electrically MIG welded.

Frame Coating: Electrostatic powder coated application oven cured.

Hardware: All stainless steel hardware fasteners.

Dimensions: 8' bench inground with back. Seat and back are 10" wide x 96" long. Seat height is 18". Seat back height is 34-1/16". Total depth of seat with back is 44".

COMPONENTS

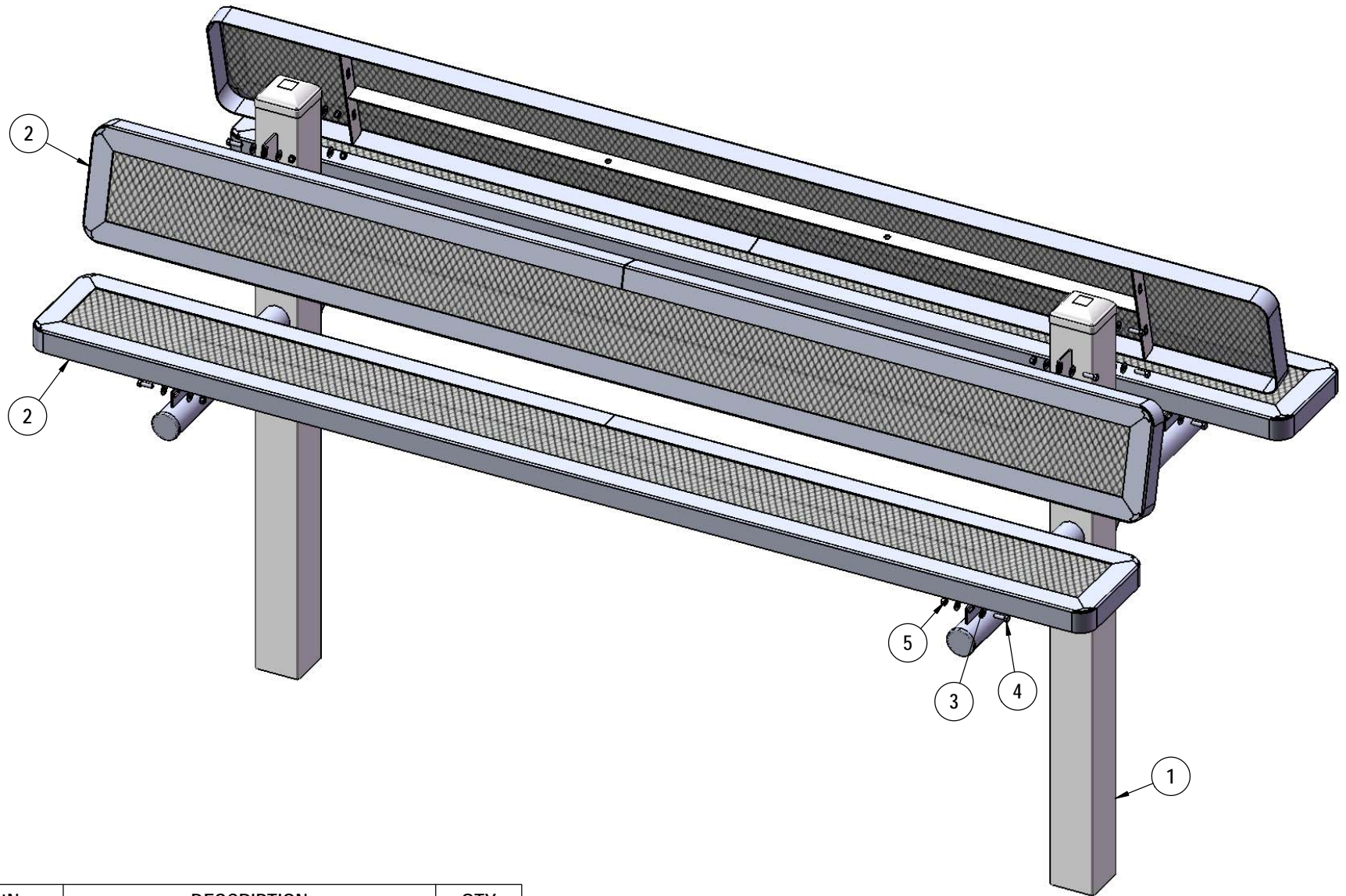

ITEM NO.	PartNo	DESCRIPTION	QTY
1	P-V962S	962 Vinyl Inground Leg	2
2	RC96-S	8' long x 10" wide regal expanded seat	4
3	33-02-0007	5/16" SS Washer	32
4	33-05-0029	5/16" x 1" Machine Bolt (SS)	16
5	33-03-0012	5/16" Kep Nut (SS)	16

Superior[®]
 RECREATIONAL PRODUCTS
 A PLAYCORE Company

STEP 1

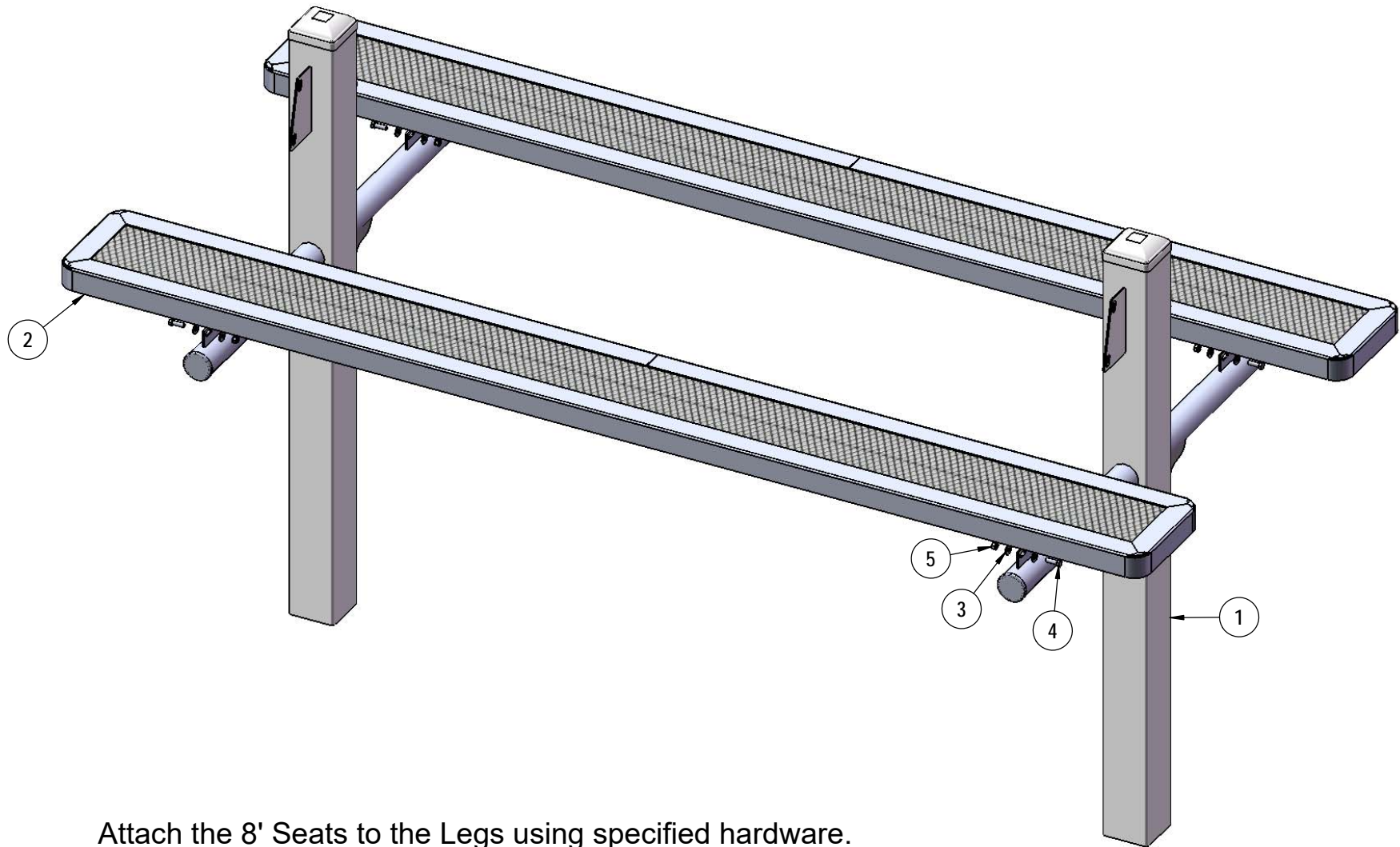

Attach the 8' Seats to the Legs using specified hardware.

STEP 2

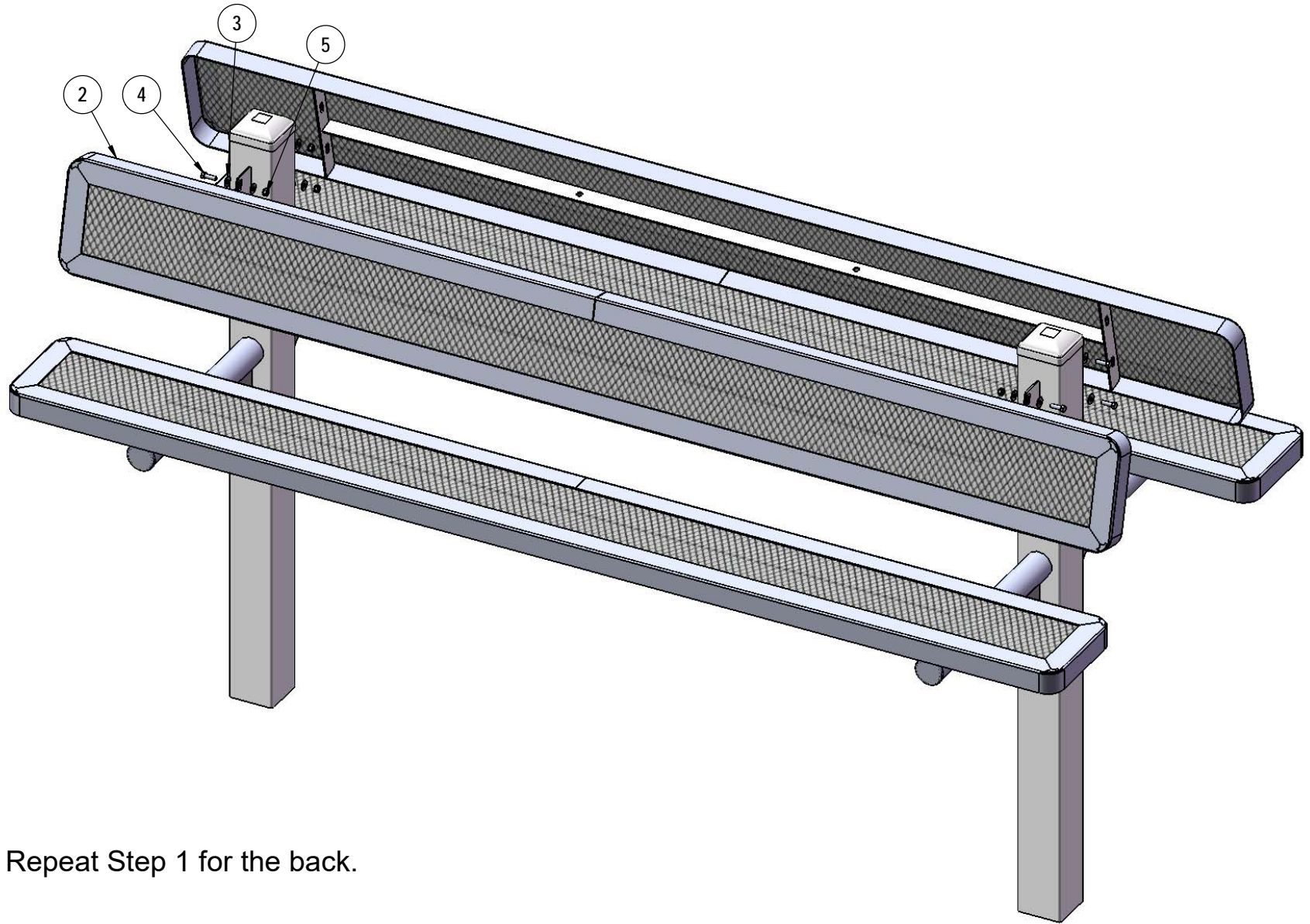

Repeat Step 1 for the back.

FOOTINGS

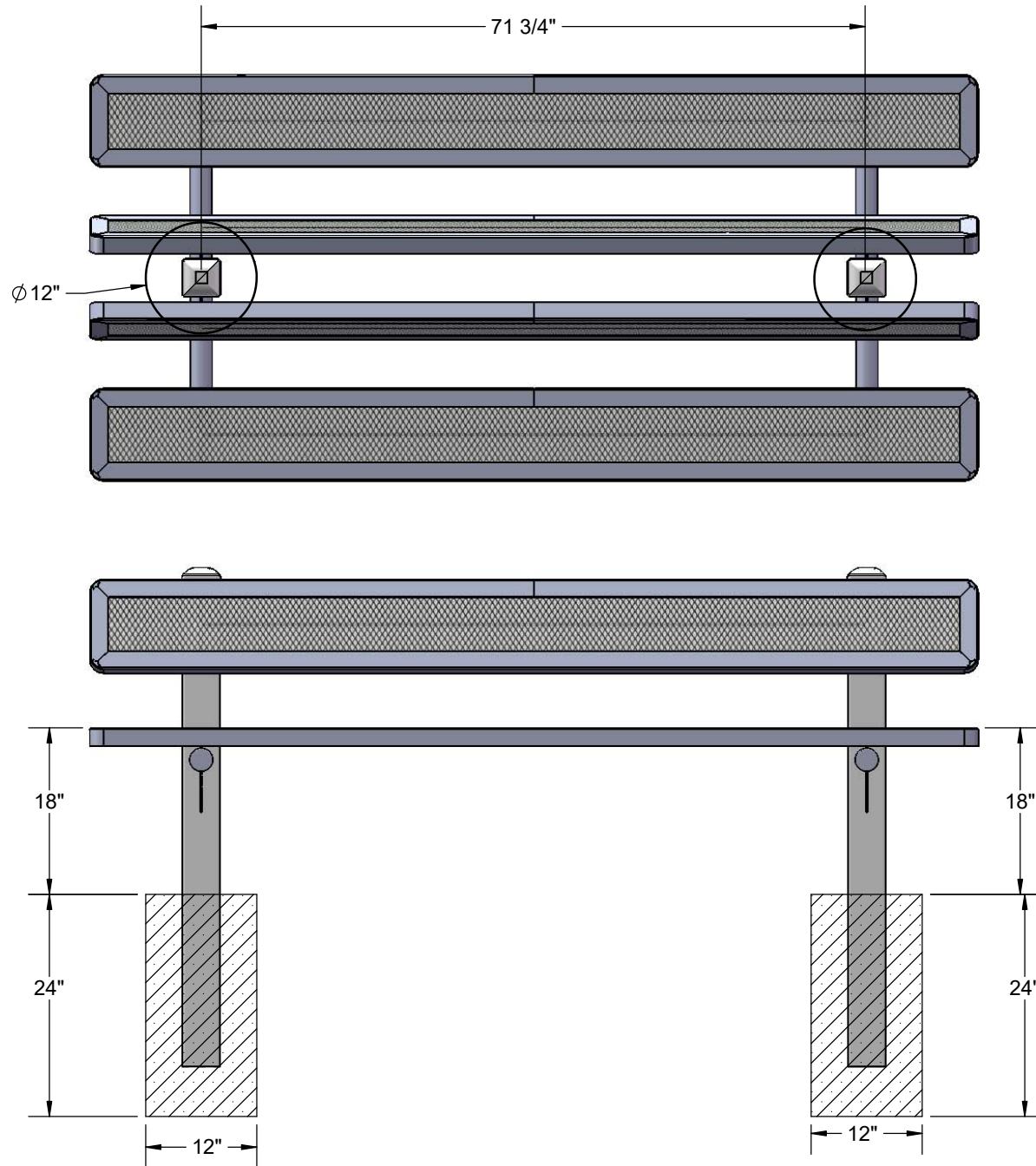

Estimated Required Concrete:
9 - 50lb Bags of Concrete Mix

OVERALL DIMENSIONS

