

Site Amenities

BY SUPERIOR RECREATIONAL PRODUCTS

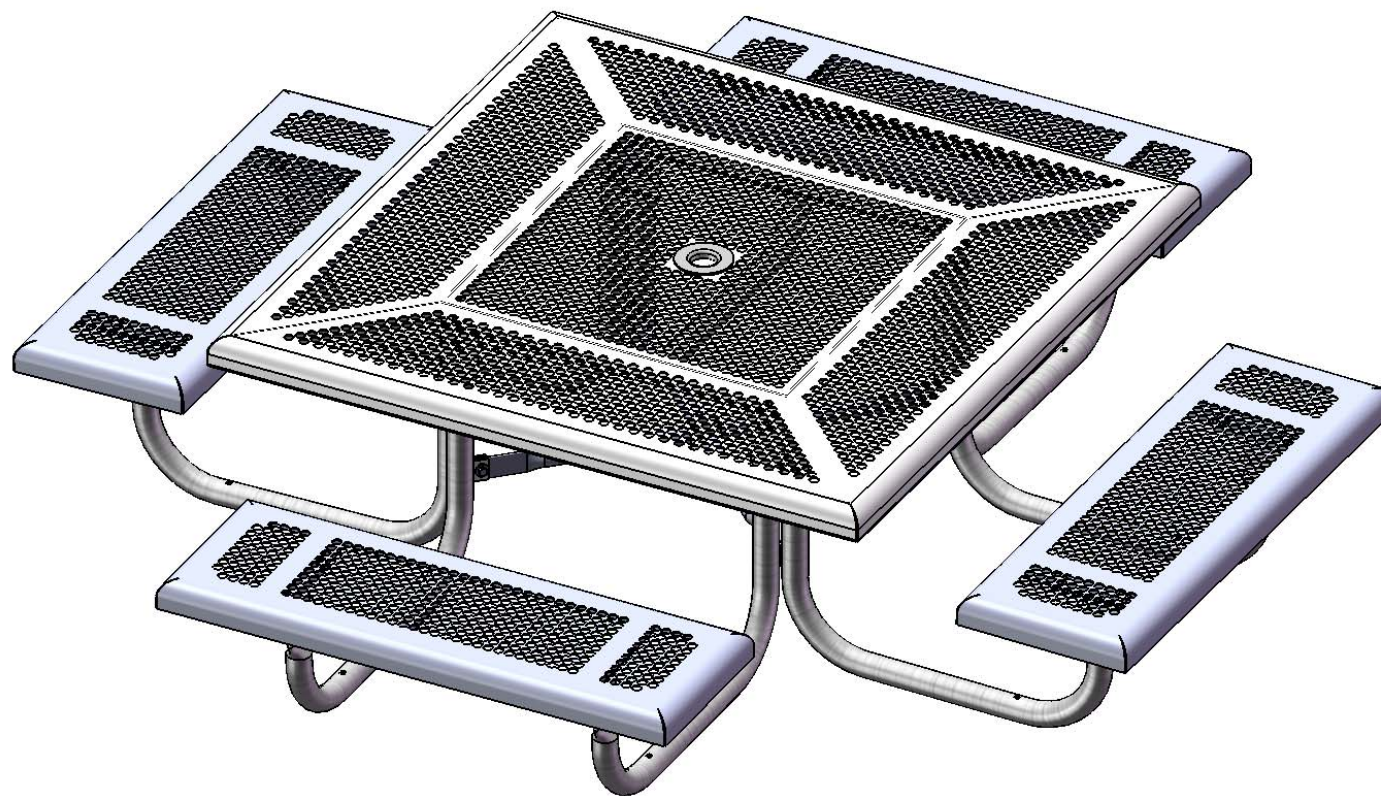

Model #
T46PERF-ELEM

S SUPERIOR[®]
RECREATIONAL PRODUCTS
A PLAYCORE Company

HARDWARE

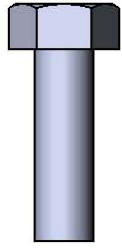

5/16" x 1"
Machine Bolt

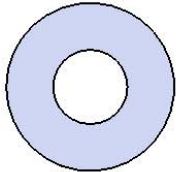

5/16" Washer

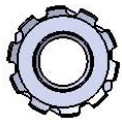

5/16" Kep Nut

PRODUCT SPECIFICATIONS

T46PERF-ELEM 46" PORTABLE TABLE WITH 4 SEATS

Top & Seats: Top and seats shall have a 1 ½" radius edge, fabricated from 12 ga. plate with a bottom lip for added strength. Holes are precision punched at 5/8" diameter to create the punched hole pattern. The understructure/attachment plates are fabricated from 7 gauge x 1-1/2" flat bar. Top is additionally supported to the outer frame with 7 gauge x 1-1/2" flat bar. Electrically MIG welded.

Coating: Oven fused functionalized polyethylene copolymer-based thermoplastic. Fluidized bed coating application with superior mechanical performance, impact resistance and UV-stability.

Frame: 1-5/8" O.D. x 14 gauge pre-galvanized structural steel tubing. Brace attachment points are 1-1/2"x2"x3/16" steel flat bar. Cross braces 1" O.D. x 16 gauge pre-galvanized structural steel tubing. Top is attached with 7 gauge 2"x2" die formed angle. Seat mounting points are 7 gauge x 1-1/2" die stamped steel flat bar. Legs are bent over a mandrel through the bend radius producing a wrinkle free bend. All electrically MIG welded.

Frame Coating: Electrostatic powder coated application oven cured.

Hardware: All stainless steel hardware fasteners.

Dimensions: Top is 46" square x 20" high. Seats are 12" wide x 36" long x 12-1/4" high. Outside to outside dimensions of 4 seat table is 77-1/2" square.

COMPONENTS

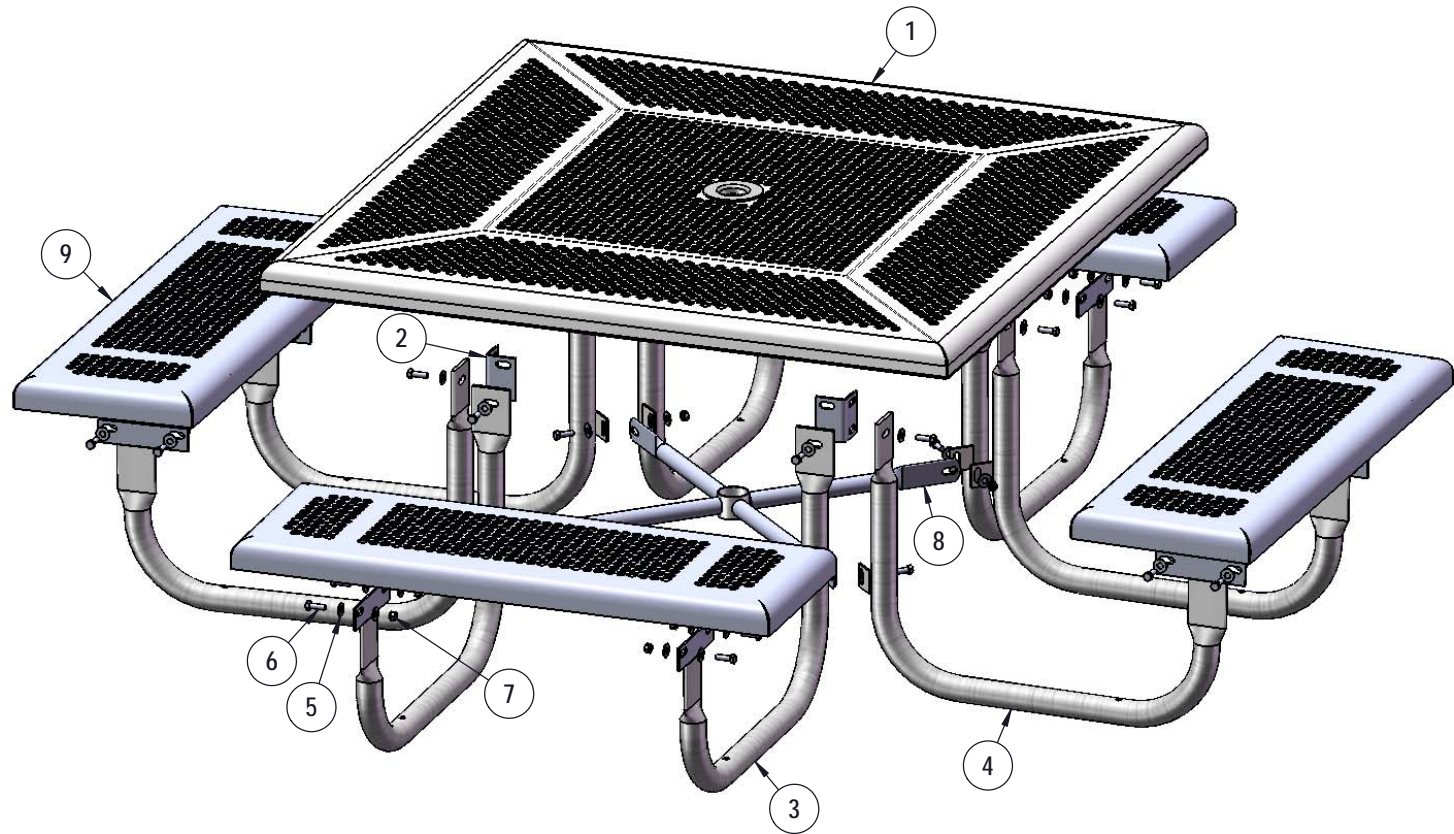

ITEM NO.	PartNo	DESCRIPTION	QTY
1	T-PR46-T	46" Square Punched Rolled Top	1
2	P-01-04-0121	358 Extension Tab	4
3	P-V358PS-R	358 Preschool Vinyl Leg R	4
4	P-V358PS-L	358 Preschool Vinyl Leg L	4
5	33-02-0007	5/16" SS Washer	72
6	33-05-0029	5/16" x 1" Machine Bolt (SS)	36
7	33-03-0012	5/16" Kep Nut (SS)	36
8	P-01-04-0122	358 Crossbrace w/ Umbrella Tube	1
9	T-PR36-S	3' Punched Rolled Seat	4

STEP 1

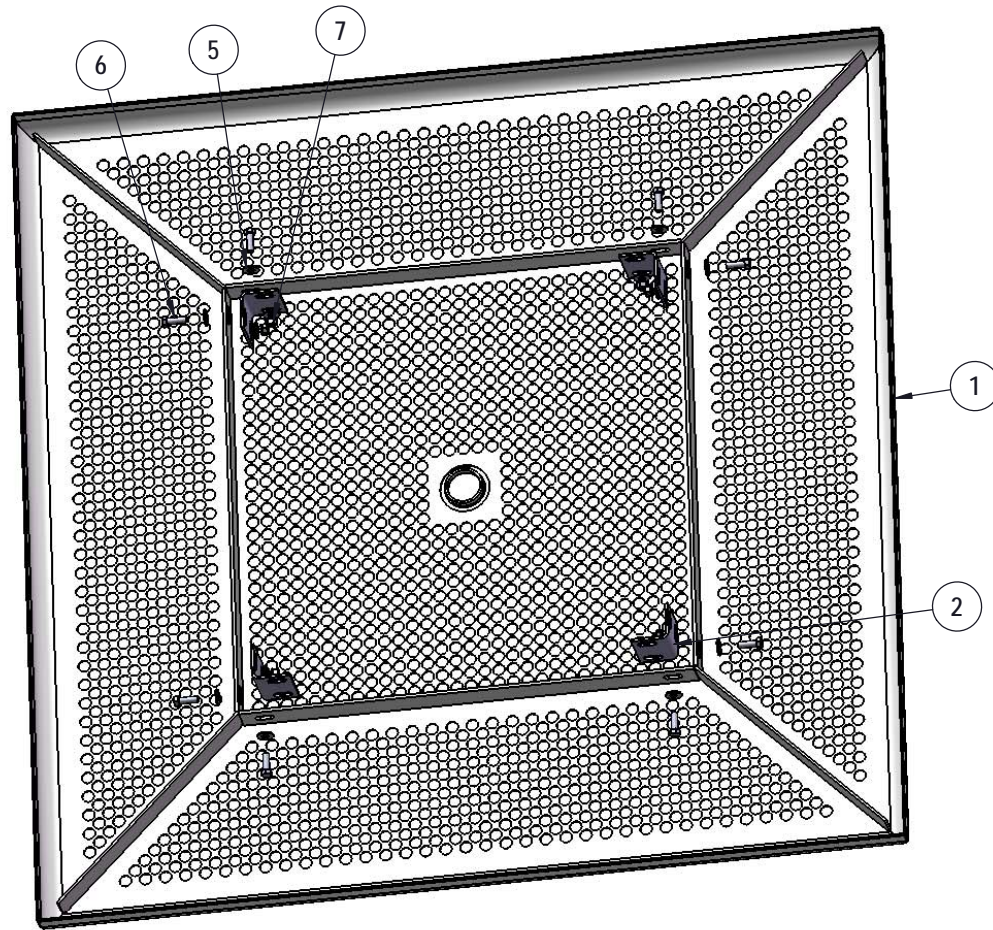

Attach the Extension Tabs to the 46" Table Top as shown using specified hardware.

STEP 2

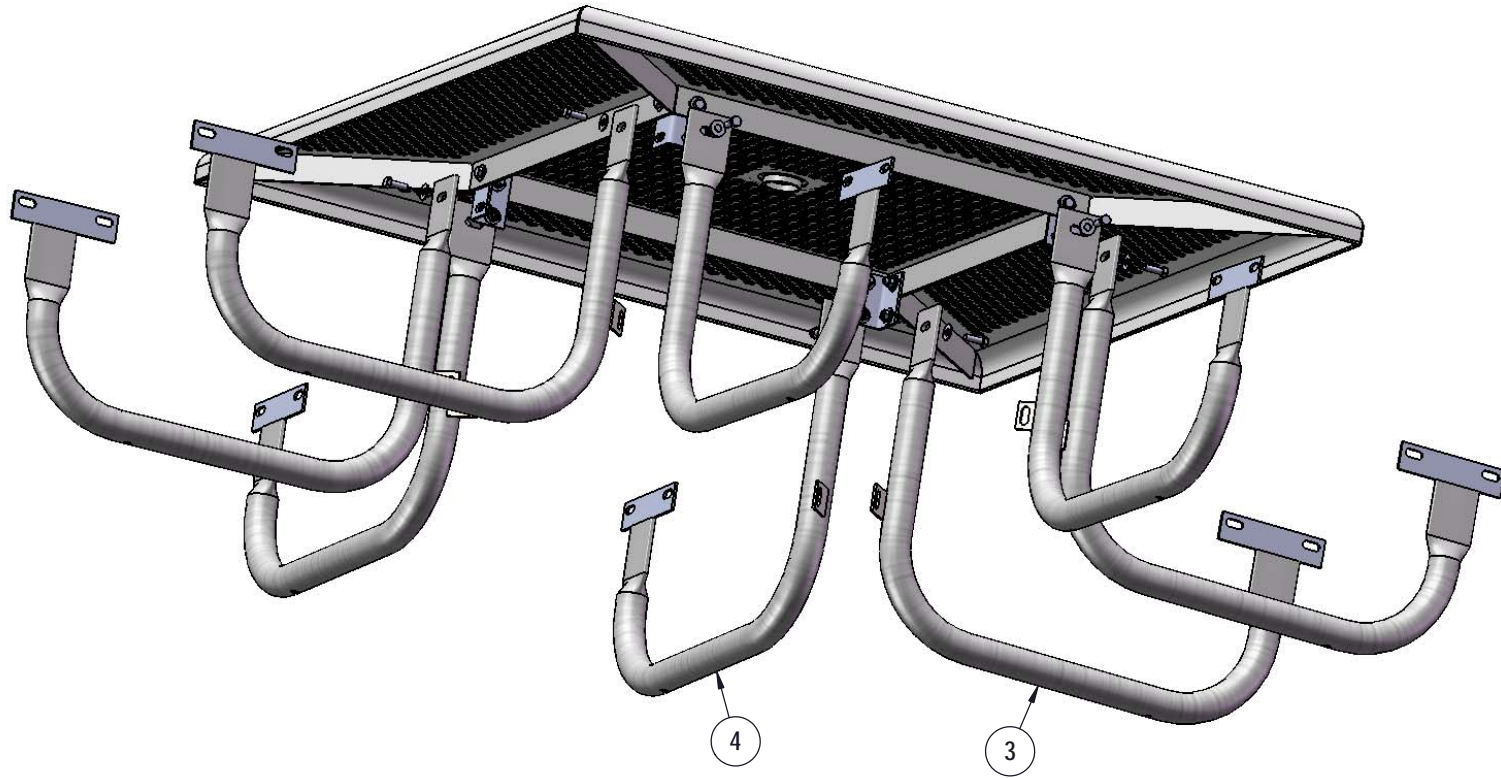

Attach the Legs to the Extension Tabs as shown using specified hardware.

STEP 3

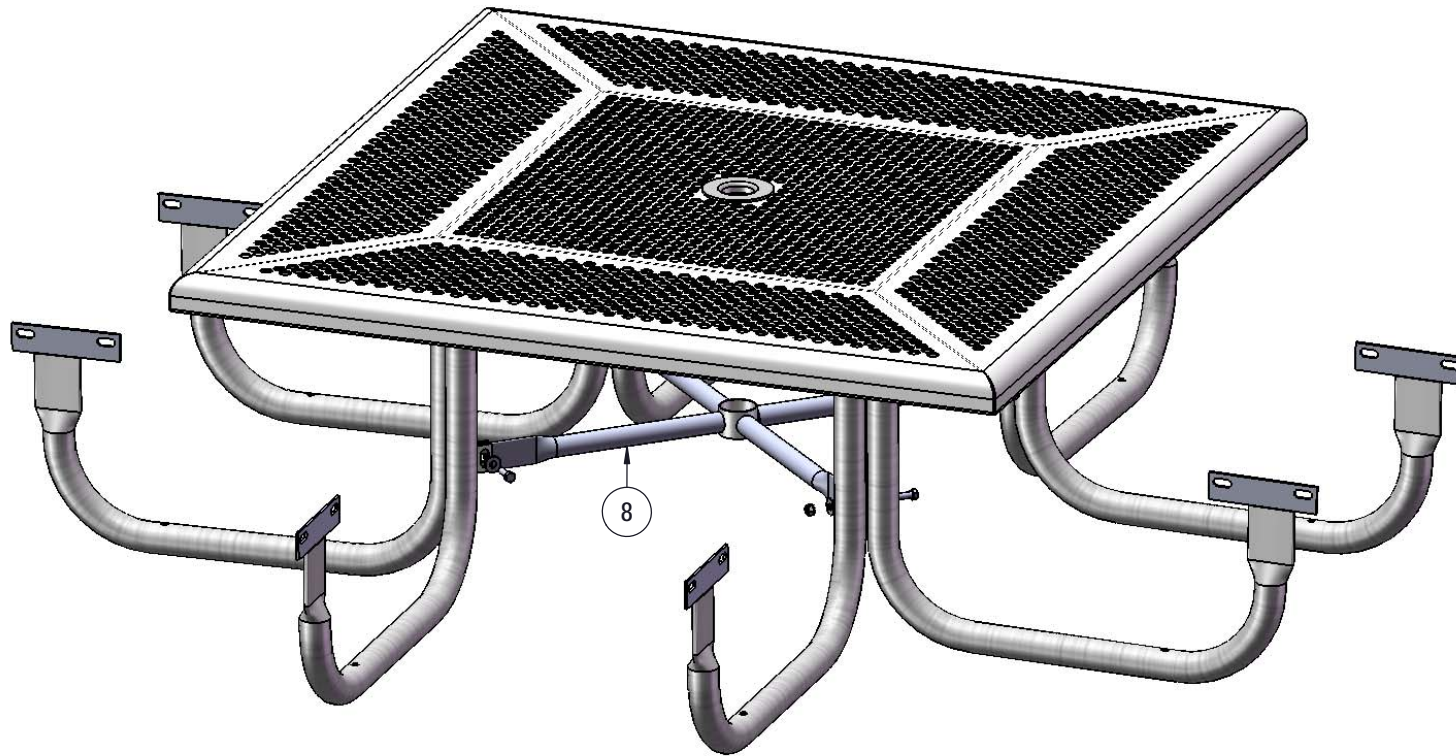

Attach the Crossbrace between the Table Legs as shown using specified hardware.

STEP 4

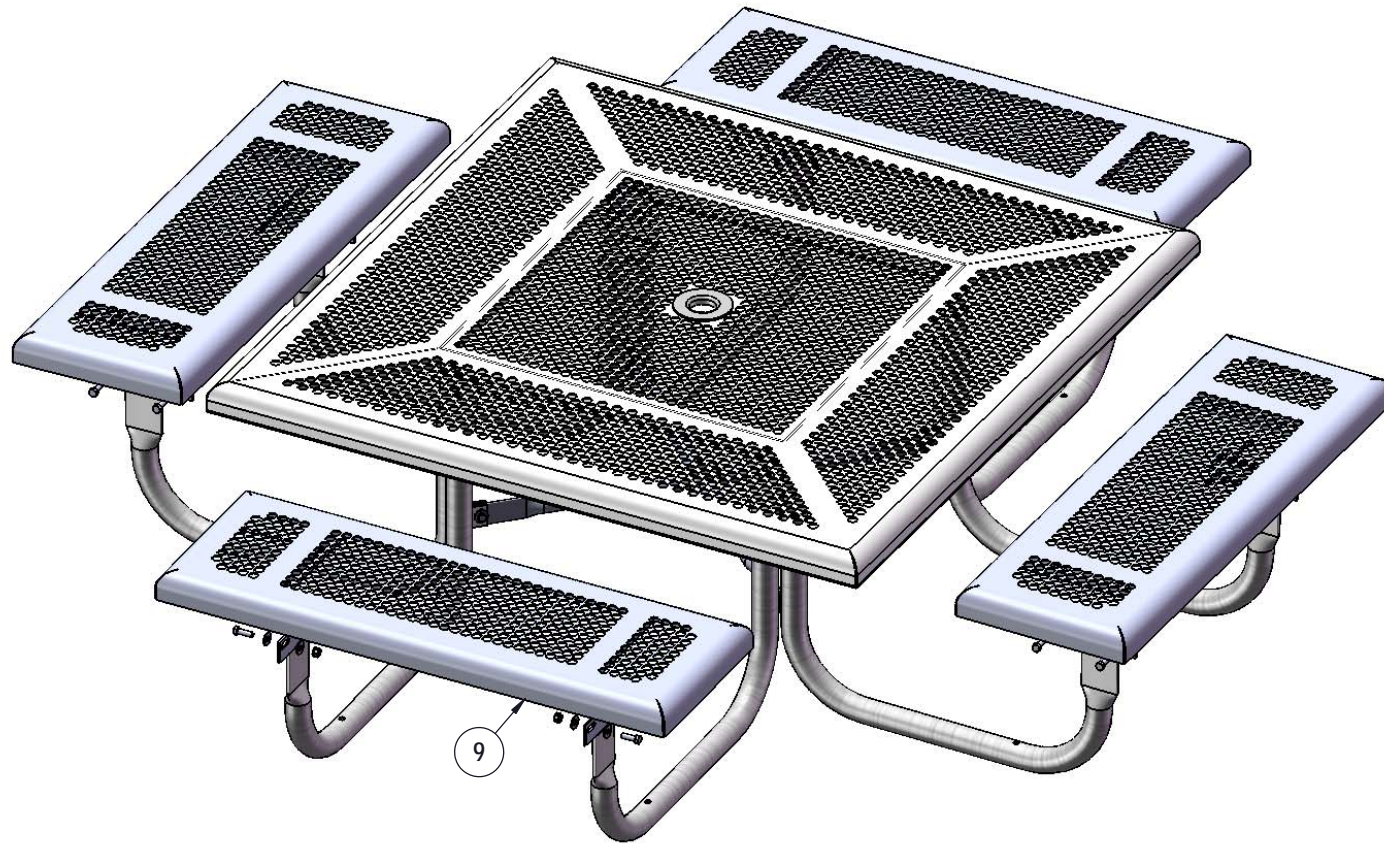

Attach the 3' Seats to the Legs as shown using specified hardware.

OVERALL DIMENSIONS

