

# Site Amenities

BY SUPERIOR RECREATIONAL PRODUCTS



Model # T46RACSPED-3SM

**S** SUPERIOR<sup>®</sup>  
RECREATIONAL PRODUCTS  
A PLAYCORE Company

# HARDWARE

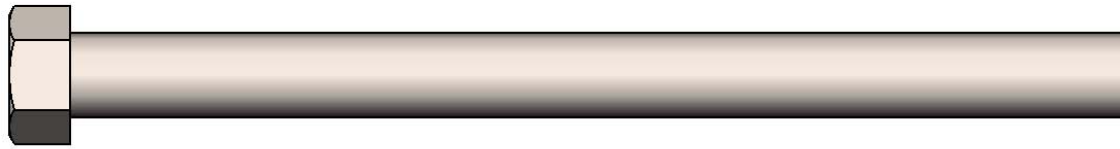

7/16" x 5-1/2"  
Machine Bolt

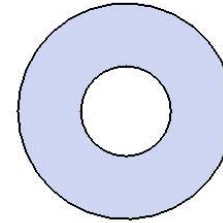

7/16" Washer

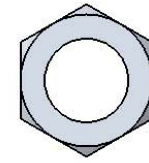

7/16" Hex Nut



5/16" x 1"  
Machine Bolt

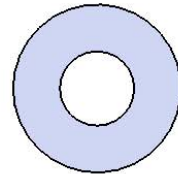

5/16" Washer

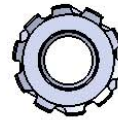

5/16" Kep Nut

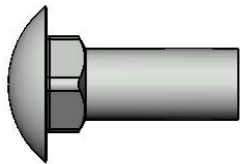

3/8" x 1"  
Carriage Bolt

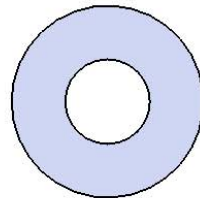

3/8" Washer

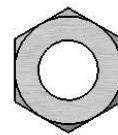

3/8" Hex Nut

## TOOLS REQUIRED

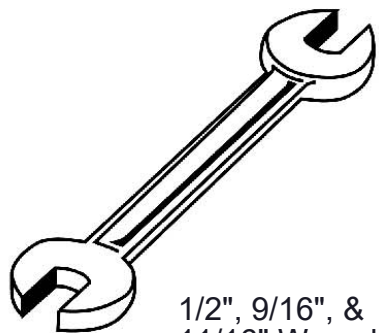

1/2", 9/16", &  
11/16" Wrench

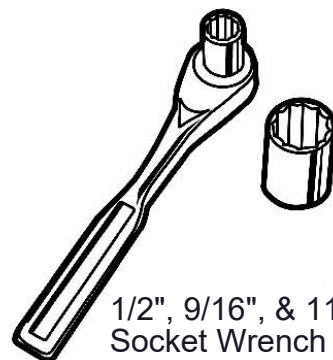

1/2", 9/16", & 11/16"  
Socket Wrench

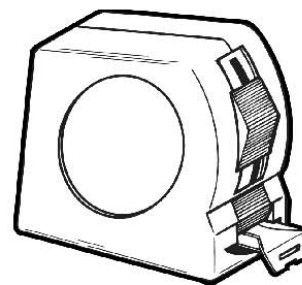

Tape Measure

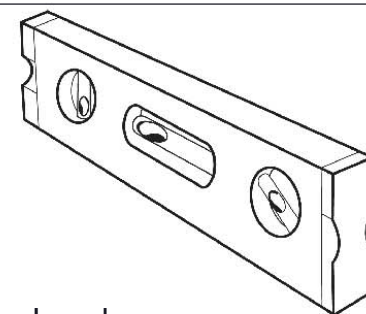

Level

# PRODUCT SPECIFICATIONS

## T46RACSPED-3SM 46" ROUND SURFACE MOUNT TABLE WITH 3 SEATS

**Top & Seats:** 11 gauge die formed angle frame 1"x1-7/8" with 3" radius on the seat corners. 3/4" #9 steel expanded metal. 7 gauge x 1-1/2" flat bar center support and mounting bracket understructure. Top is additionally supported to the outer frame with 7 gauge x 1-1/2" flat bar. Electrically MIG welded.

**Coating:** Oven fused functionalized polyethylene copolymer-based thermoplastic. Fluidized bed coating application with superior mechanical performance, impact resistance and UV-stability.

**Frame:** Main support column is 4"x4"x11 gauge pre-galvanized structural steel tubing. Arms are fabricated from 2-7/8" O.D. x 12 gauge pre-galvanized structural steel tubing welded to 1/4" precision punched plates for attachment to the main column and 2"x2"x3/16" structural steel angle for lateral seat support. Seat attachment points are 10 gauge precision punched tabs. Table top attachment structure is fabricated from 1/4" formed steel and top attachment points are 7 gauge x 1-1/2" steel flat bar. Surface mount plate is 16" x 16" x 1/2" thick. All electrically MIG welded.

**Frame Coating:** Electrostatic powder coated application oven cured.

**Hardware:** All stainless steel hardware fasteners.

**Dimensions:** Top is 46" diameter x 30-1/4" high. Seats are 12" wide x 40" long x 18" high. Outside to outside dimensions of 3 seat table is 63-1/2" x 81".

# COMPONENTS

Recommended Surface Mount Hardware:  
3/8" x 3-1/2" Concrete Expansion Anchor Bolts  
(Not Included)

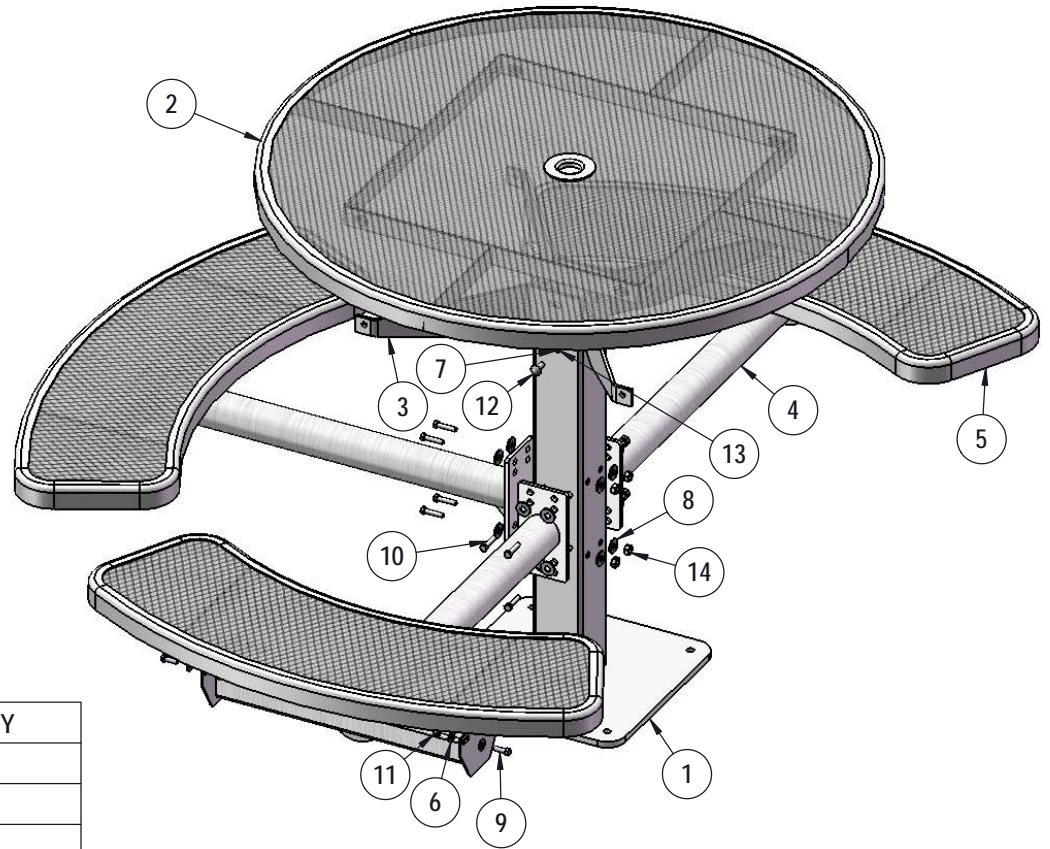

ITEM NO.	PartNo	DESCRIPTION	QTY
1	338SM	338 SM post asem	1
2	T-V46RD-T	46" Round Expanded Top	1
3	P-01-04-0150	H Bracket	1
4	P-V338-ARM	338 vinyl arm	3
5	T-V36RD-S	3' Expanded Round Seat	3
6	33-02-0007	5/16" SS Washer	32
7	33-02-0008	3/8" Flat Washer (SS)	4
8	33-02-0004	7/16" SS Washer	16
9	33-05-0029	5/16" x 1" Machine Bolt (SS)	16
10	33-05-0005	5/16" x 1 1/2" Machine Bolt (Zinc)	8
11	33-03-0012	5/16" Kep Nut (SS)	16
12	33-06-0042	3/8" x 1" Carriage Bolt (SS)	4
13	33-01-0018	3/8" Hex Nut (SS)	4
14	33-01-0006	7/16" Hex Nut (SS)	8

# STEP 1

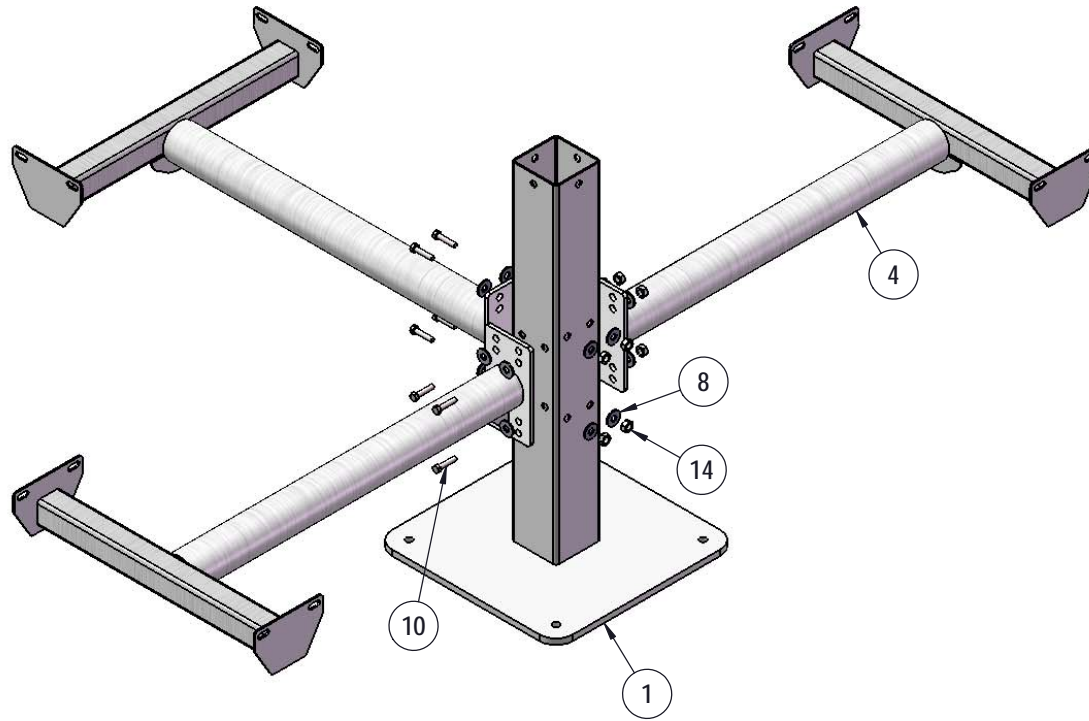

Attach the 338 Vinyl Arms to the 338 Post using specified hardware.



## STEP 2

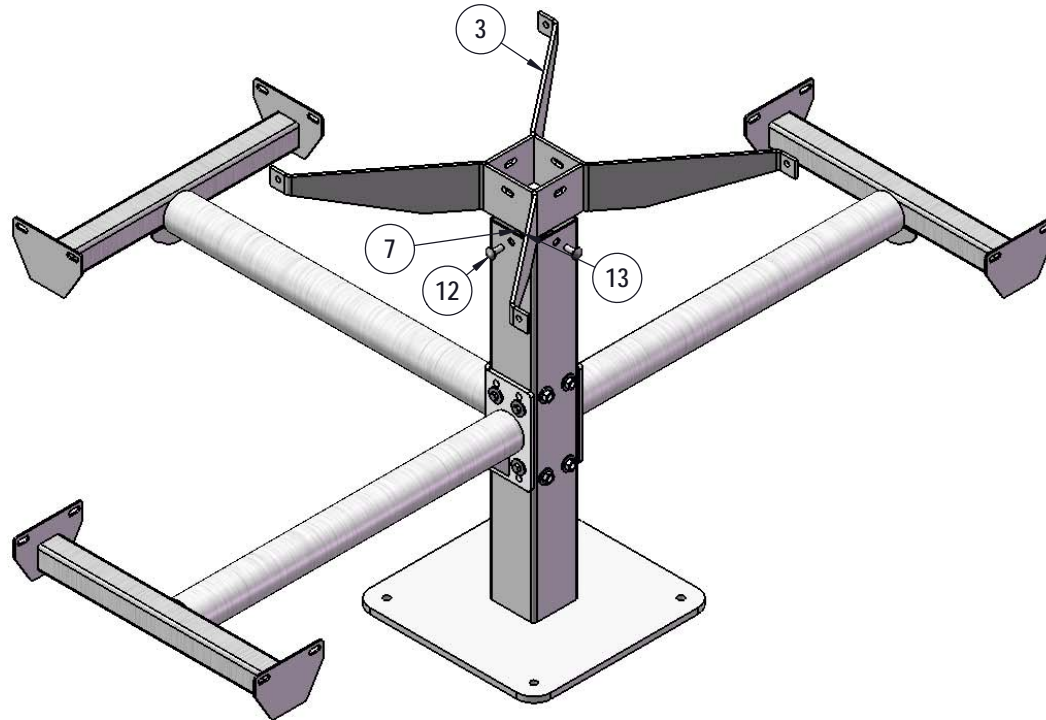

Attach the H Bracket to the 338 Post using specified hardware.

## STEP 3

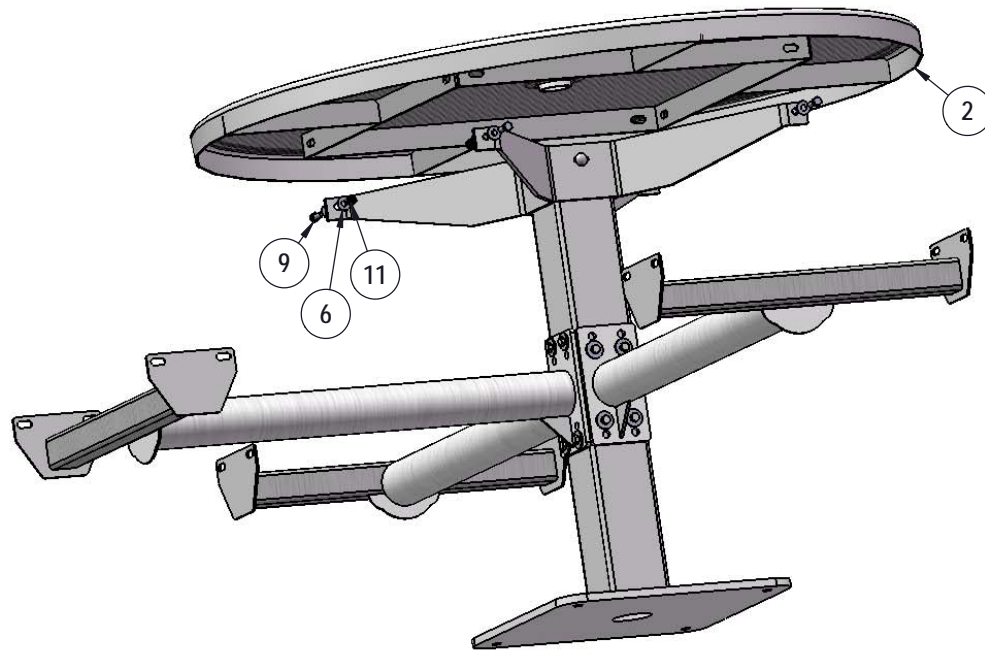

Attach the 46" Round Top to the H Bracket using specified hardware.



## STEP 4

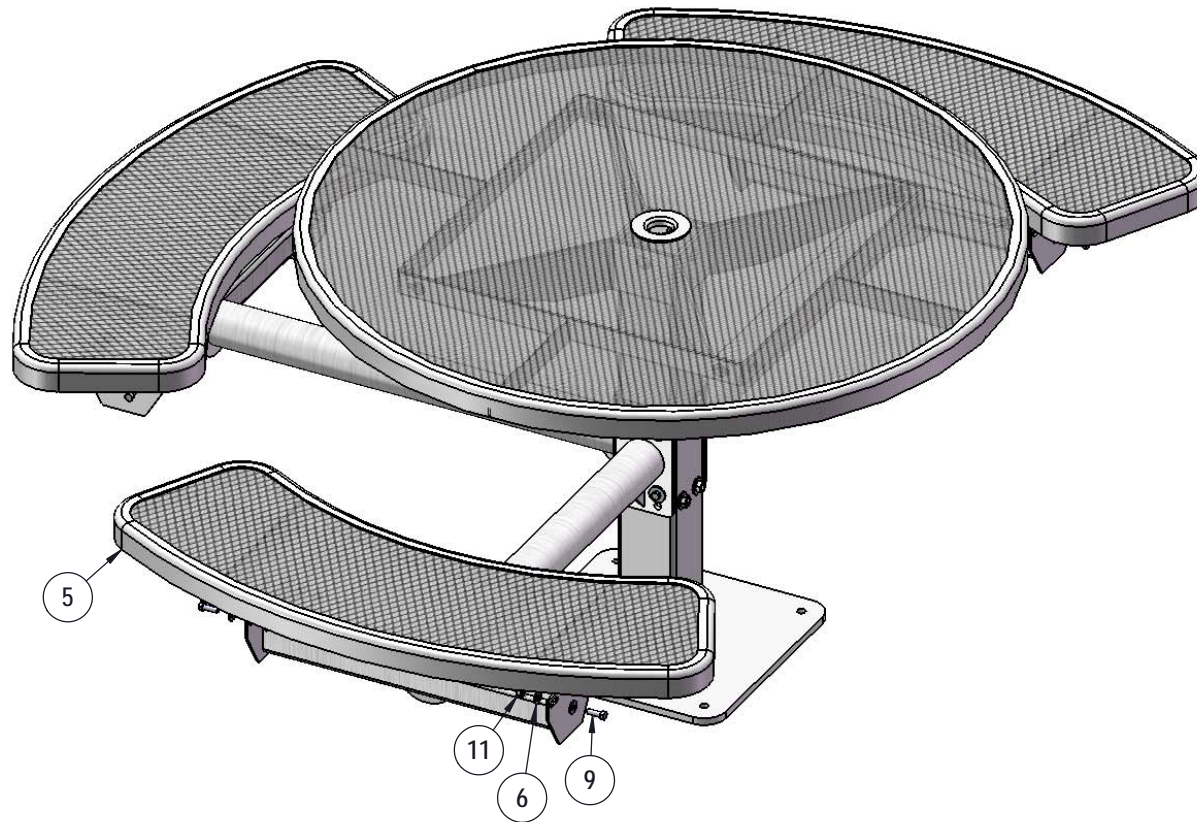

Attach the 3' Round Seats to the 338 Vinyl Arms using specified hardware.

# OVERALL DIMENSIONS

