

# Site Amenities

BY SUPERIOR RECREATIONAL PRODUCTS

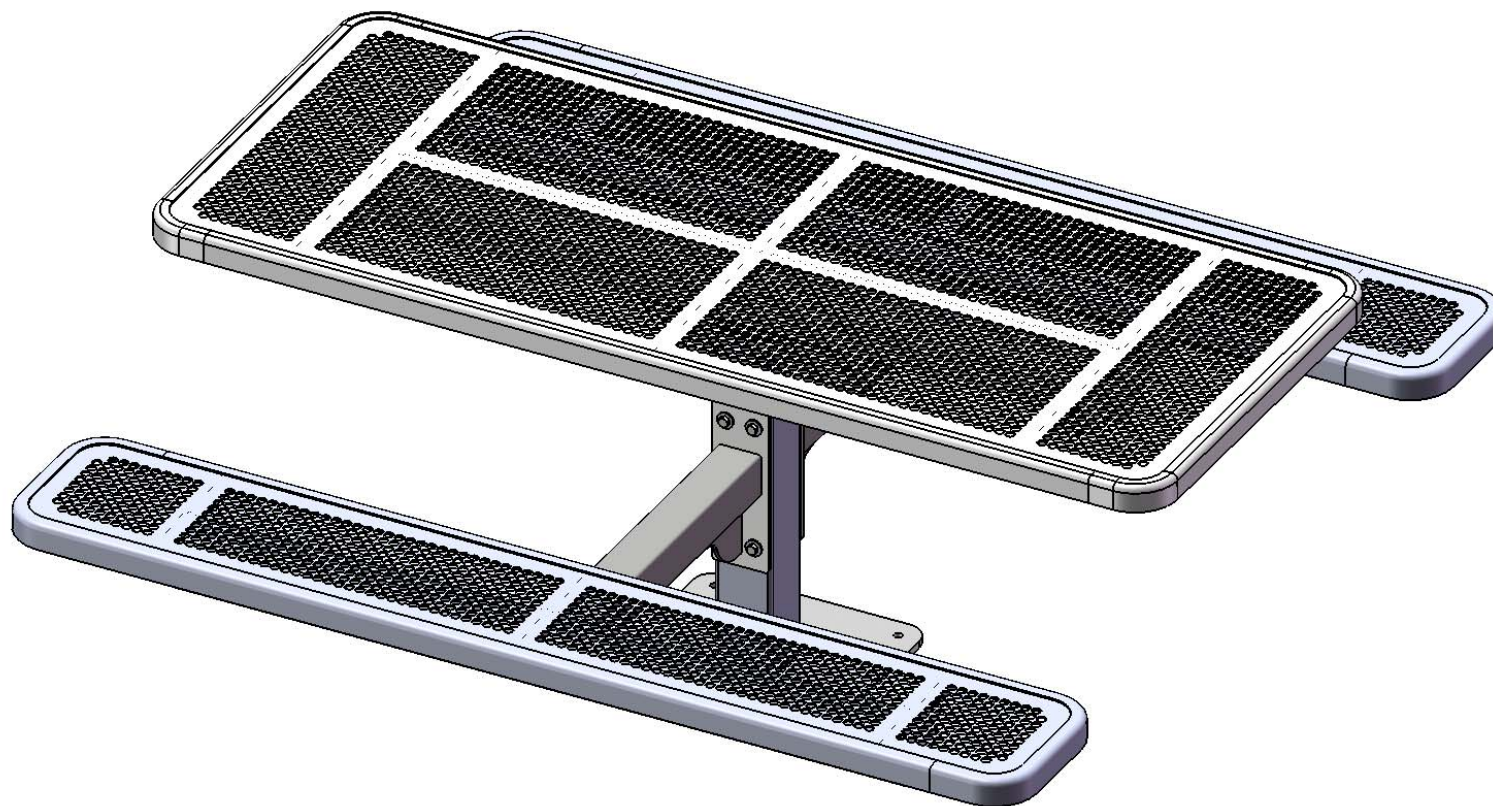

Model #  
T6INNVPEHDHDCPSM  
T6INNVPEDSM

 **SUPERIOR**<sup>®</sup>  
RECREATIONAL PRODUCTS  
A **PLAYCORE** Company

# HARDWARE



5/16" x 1"  
Machine Bolt

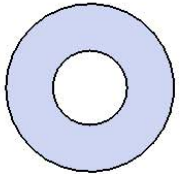

5/16" Washer



5/16" Kep Nut

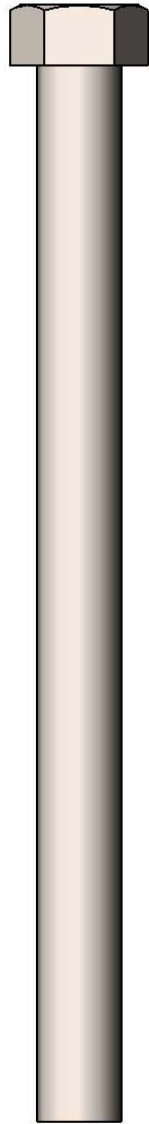

7/16" x 5-1/2"  
Machine Bolt

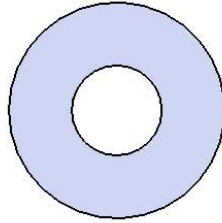

7/16" Washer

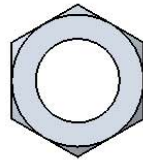

7/16" Hex Nut



3/8" x 4"  
Carriage Bolt

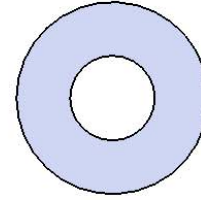

3/8" Washer

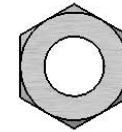

3/8" Hex Nut

# PRODUCT SPECIFICATIONS

## **T6INNVPEHDHDCPSM T6INNVPEDSM RECTANGULAR SURFACE MOUNT TABLE**

Top & Seats: 11 gauge die formed angle frame 1"x1-7/8" with 3" radius corners. 12 gauge sheet steel is precision punched with a 5/8" hole. 7 gauge x 1-1/2" flat bar center support and mounting bracket understructure. Electrically MIG welded.

Coating: Oven fused functionalized polyethylene copolymer-based thermoplastic. Fluidized bed coating application with superior mechanical performance, impact resistance and UV-stability.

Frame: Main support column is 4"x 4"x 11 gauge pre-galvanized structural steel tubing with a 16" x 16" x 1/2" surface mount plate. Arms are fabricated from 3"x 3"x 11 gauge pre-galvanized structural steel tubing welded to 1/4" precision punched plates for attachment to the main column and 2"x 2"x 3/16" structural steel angle for lateral seat support. Seat attachment points are 10 gauge precision punched tabs. Table top attachment structure is fabricated from 2"x 2"x 3/16" structural steel angle and top attachment points are 7 gauge x 1-1/2" steel flat bar. All electrically MIG welded.

Frame Coating: Electrostatic powder coated application oven cured.

Hardware: All stainless steel hardware fasteners.

Dimensions: Top is 30" wide x 72" long x 30-1/2" high. Seats are 12" wide x 72" long x 19" high. Outside to outside dimensions of 67-3/4" x 72".

# COMPONENTS

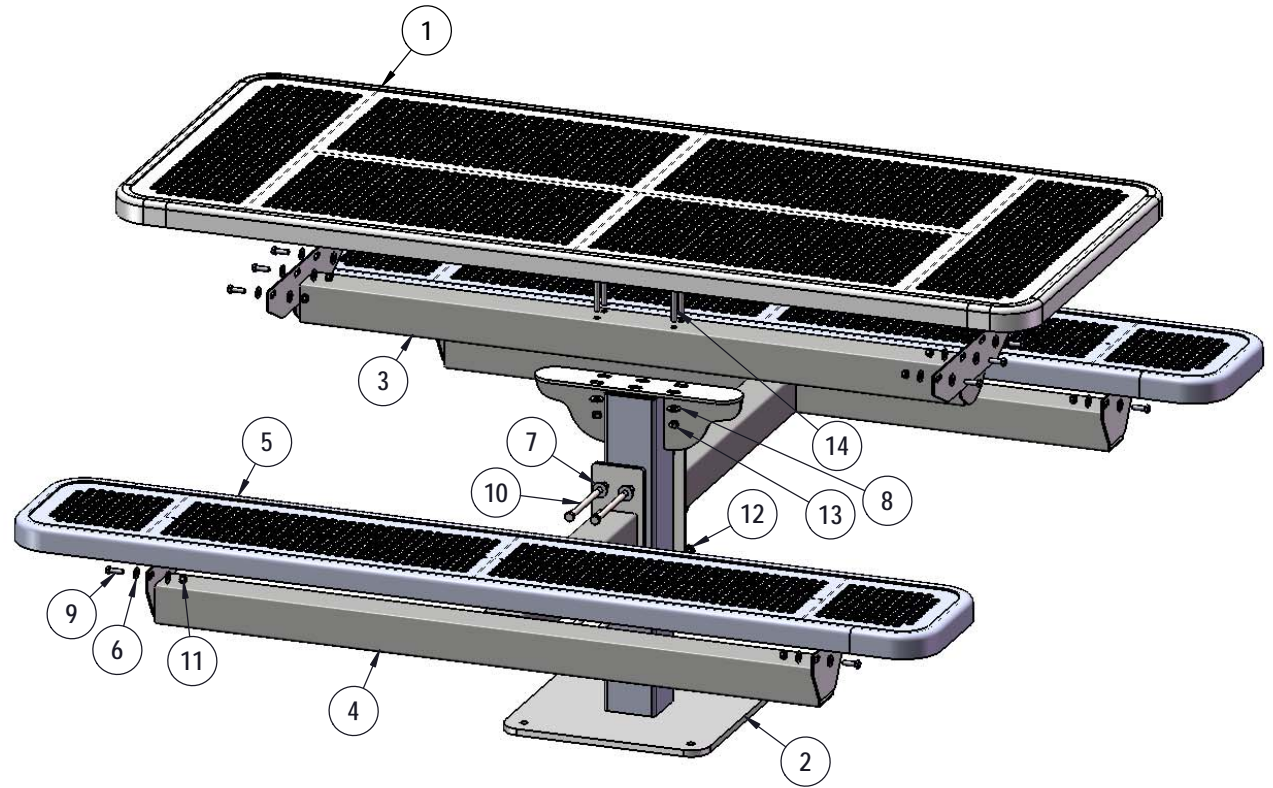

ITEM NO.	PartNo	DESCRIPTION	QTY
1	T-P72-T	6' Punched Top	1
2	337SM	SM Post Assembly	1
3	P-V337-72-T	6' 337 Top Vinyl Bracket Assembly	1
4	V337-72-S	337 6' Vinyl Seat Arm Assem	2
5	T-P72-S	6' Punched Seat	2
6	33-02-0007	5/16" SS Washer	32
7	33-02-0004	7/16" SS Washer	9
8	33-02-0008	3/8" Flat Washer (SS)	4
9	33-05-0029	5/16" x 1" Machine Bolt (SS)	16
10	33-06-0050	7/16" x 5-1/2" Machine Bolt	4
11	33-03-0012	5/16" Kep Nut (SS)	16
12	33-01-0006	7/16" Hex Nut (SS)	4
13	33-01-0018	3/8" Hex Nut (SS)	4
14	33-06-0067	3/8" x 4" Carriage Bolt (Zinc)	4

Recommended Surface Mount Hardware:  
 3/8" x 3-1/2" Concrete Expansion Anchor Bolts  
 (Not Included)

# STEP 1

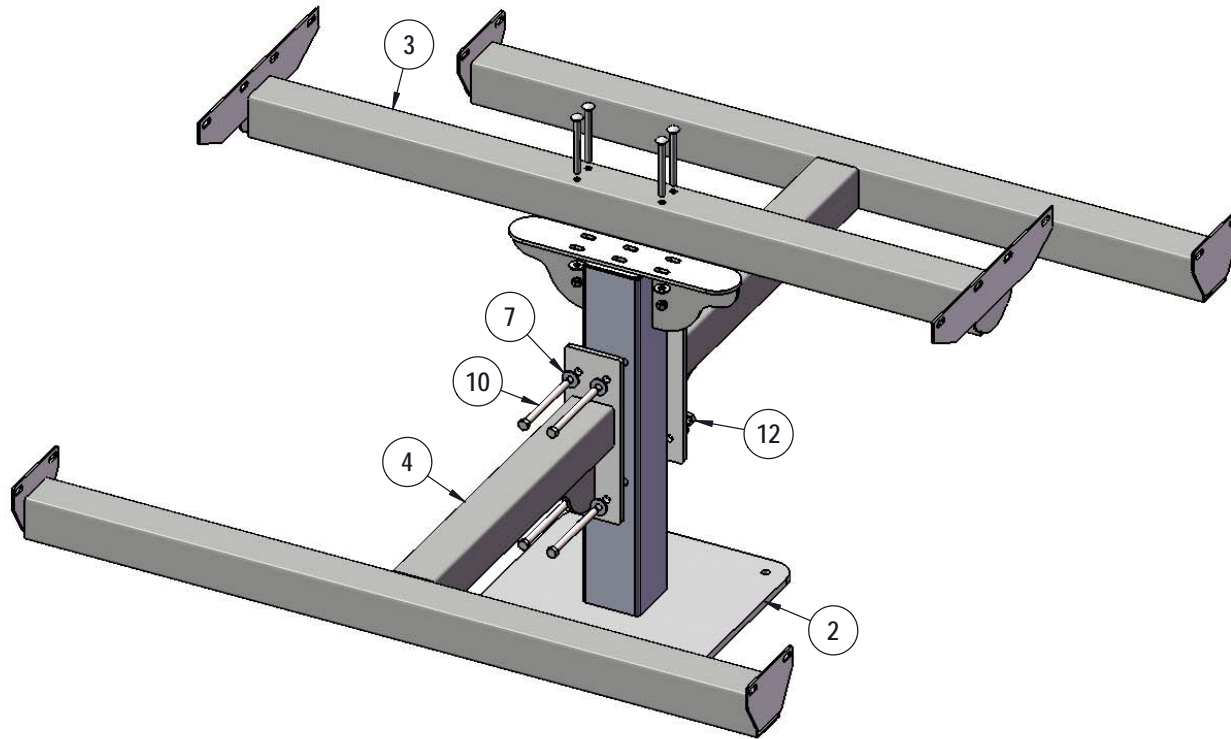

Attach the Bracket Assembly and the Seat Arm Assemblies to the 337 Post as shown using specified hardware.



## STEP 2

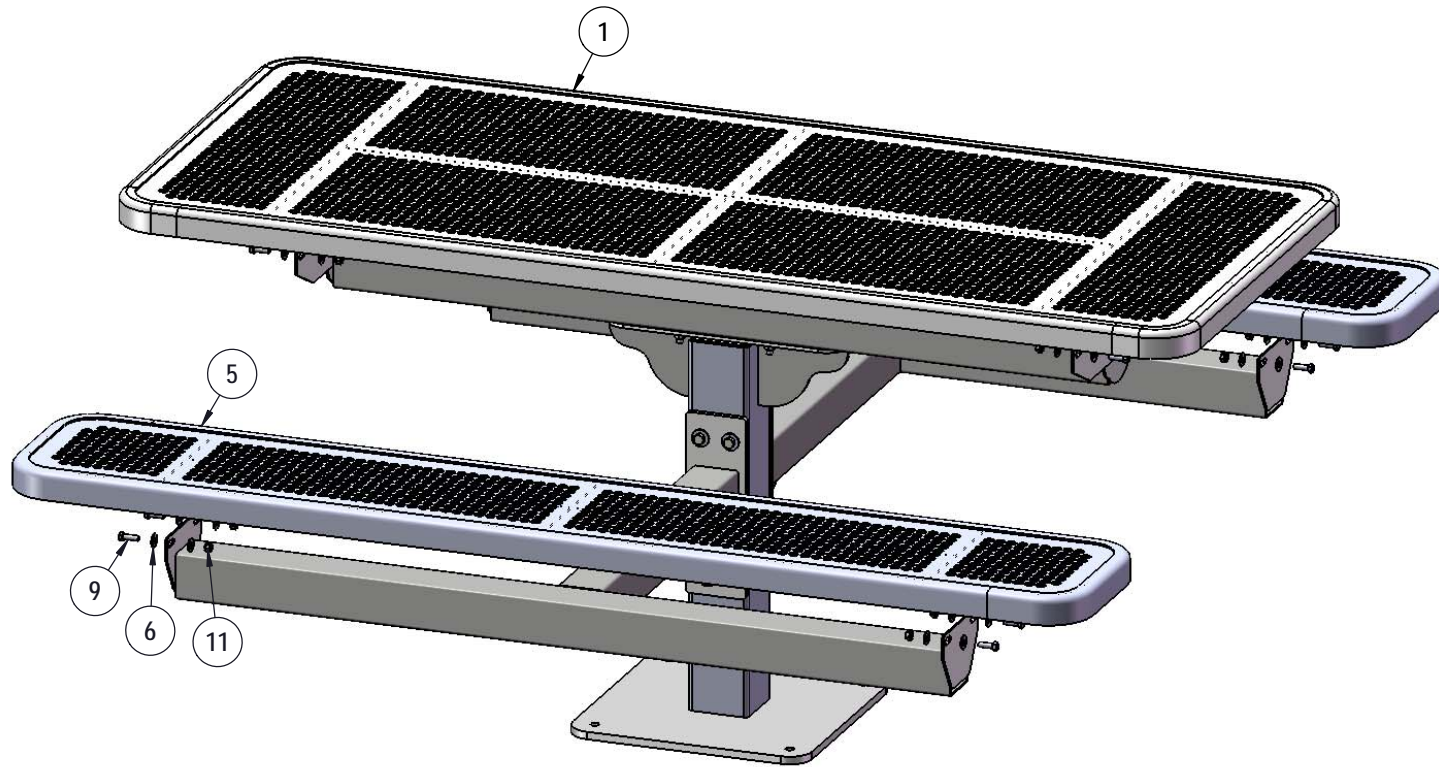

Attach the Seats and Top to the Bracket Assembly and the Seat Arms Assemblies as shown using specified hardware.

# OVERALL DIMENSIONS

