

Site Amenities

BY SUPERIOR RECREATIONAL PRODUCTS

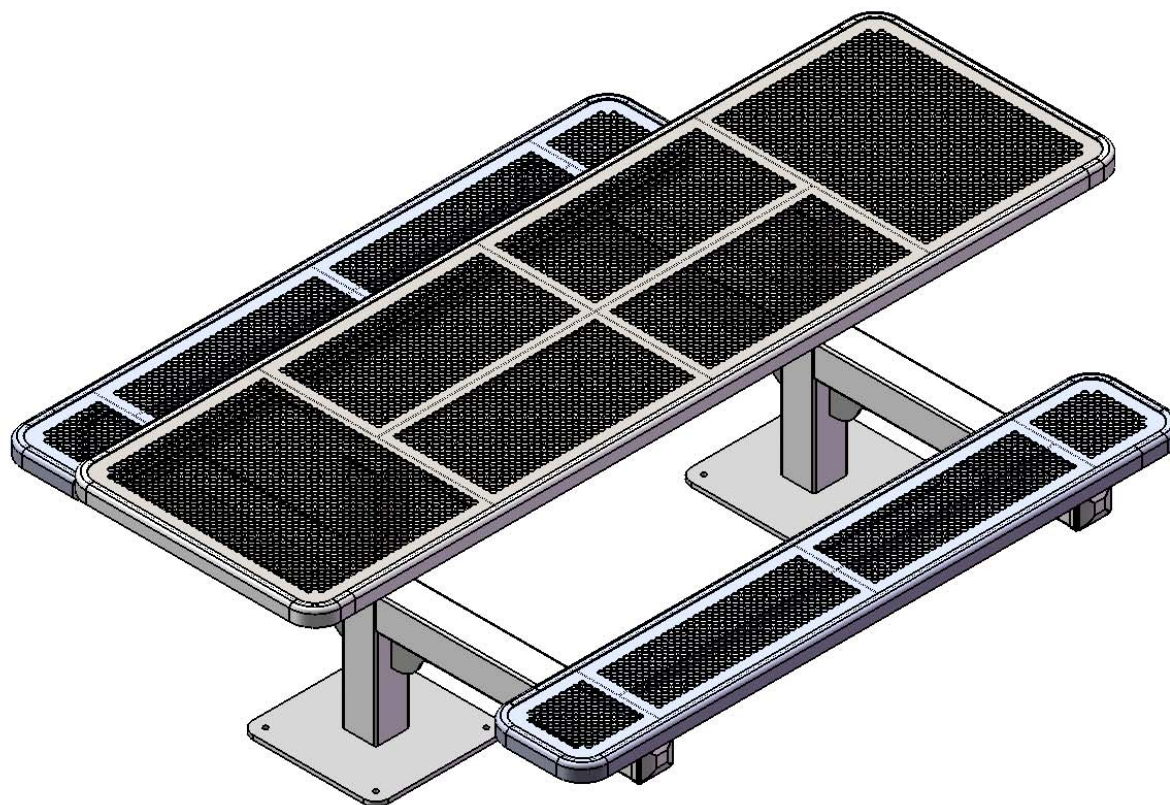

Model #
T8INNVDBLPEDHDCPSM

 **SUPERIOR**[®]
RECREATIONAL PRODUCTS
A **PLAYCORE** Company

HARDWARE

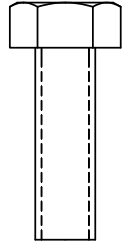

5/16" x 1"
Machine Bolt

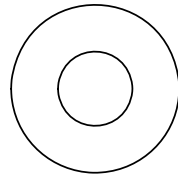

5/16" Washer

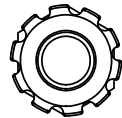

5/16" Kep Nut

PRODUCT SPECIFICATIONS

T8INNVDBLPEDHDCPSM 8' SURFACE MOUNT PICNIC DESIGN

Top & Seats: 11 gauge die formed angle frame 1"x1-7/8" with 3" radius corners. Seat and back plates are fabricated from a 12ga plate. Holes are precision punched at 5/8" diameter. 7 gauge x 1-1/2" flat bar center support and mounting bracket understructure. Electrically MIG welded.

Coating: Oven fused functionalized polyethylene copolymer-based thermoplastic. Fluidized bed coating application with superior mechanical performance, impact resistance and UV-stability.

Frame: 4 x 4 x 11 gauge structural steel square tubing. Tubing is capped with a 4 x 4 x 3/16" steel flat bar. Arms are supported with 6" x 6" x 1/4" steel flat bar gussets. Seat and top mounting points 7 gauge x 1-1/2" die stamped steel flat bar. All electrically MIG welded.

Frame Coating: Electrostatic powder coated application oven cured.

Hardware: All stainless steel hardware fasteners.

Dimensions: 8' accessible permanent picnic table design. Top is 30-1/8" wide x 96-1/8" long and is 30" high. Seats are 12-1/8" wide x 72-1/8" long and 18" high. Outside to outside dimension is 64" x 96-1/8". The table top over hangs the frame 21" on both ends.

COMPONENTS

Optional Surface Mount Hardware:
 3/8" x 3-1/2" Concrete Expansion Anchor Bolts
 (Not Included)

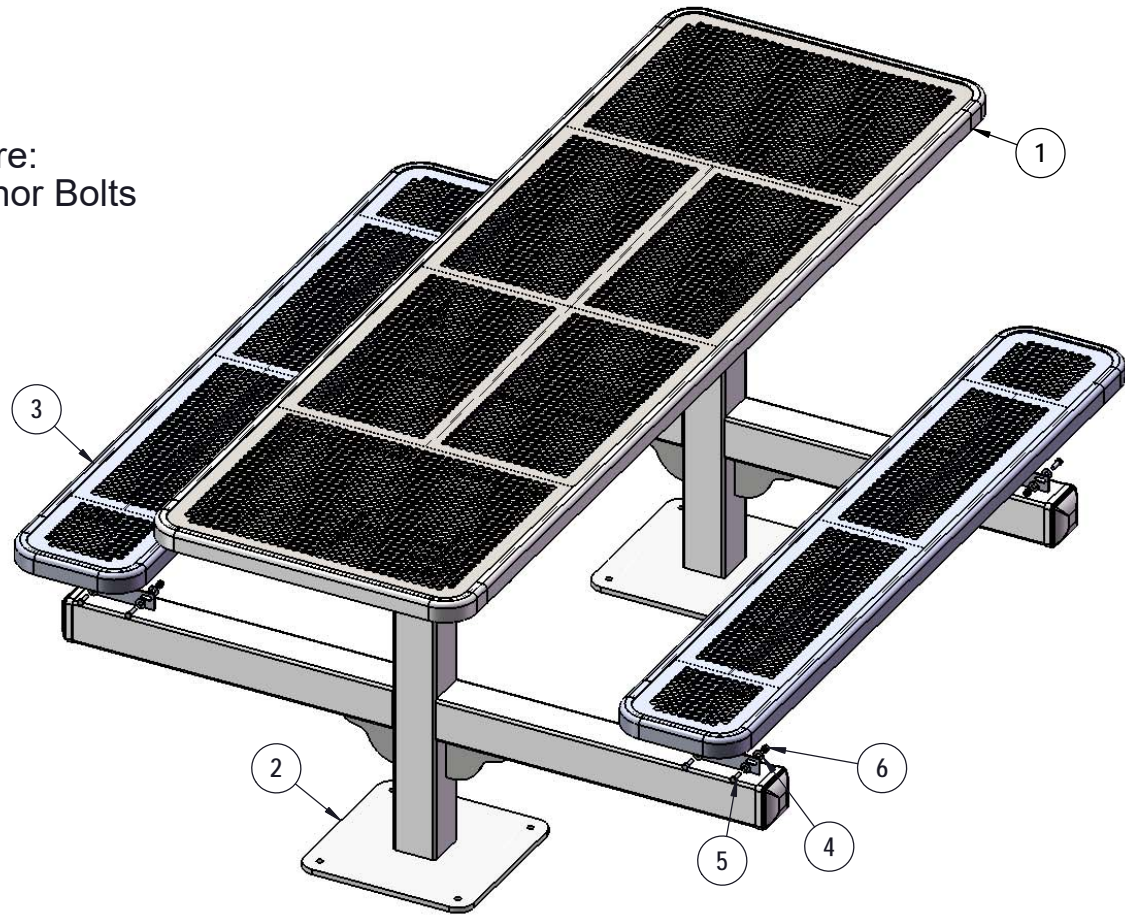

ITEM NO.	PartNo	DESCRIPTION	QTY
1	T-P96H-T	8' H Punched Top	1
2	P-V347SM	347 Surface Mount Vinyl Leg	2
3	T-P72-S	6' Punched Seat	2
4	33-02-0007	5/16" SS Washer	32
5	33-05-0029	5/16" x 1" Machine Bolt (SS)	16
6	33-03-0012	5/16" Kep Nut (SS)	16

STEP 1

Attach the 8' Table Top to the Legs using specified hardware.

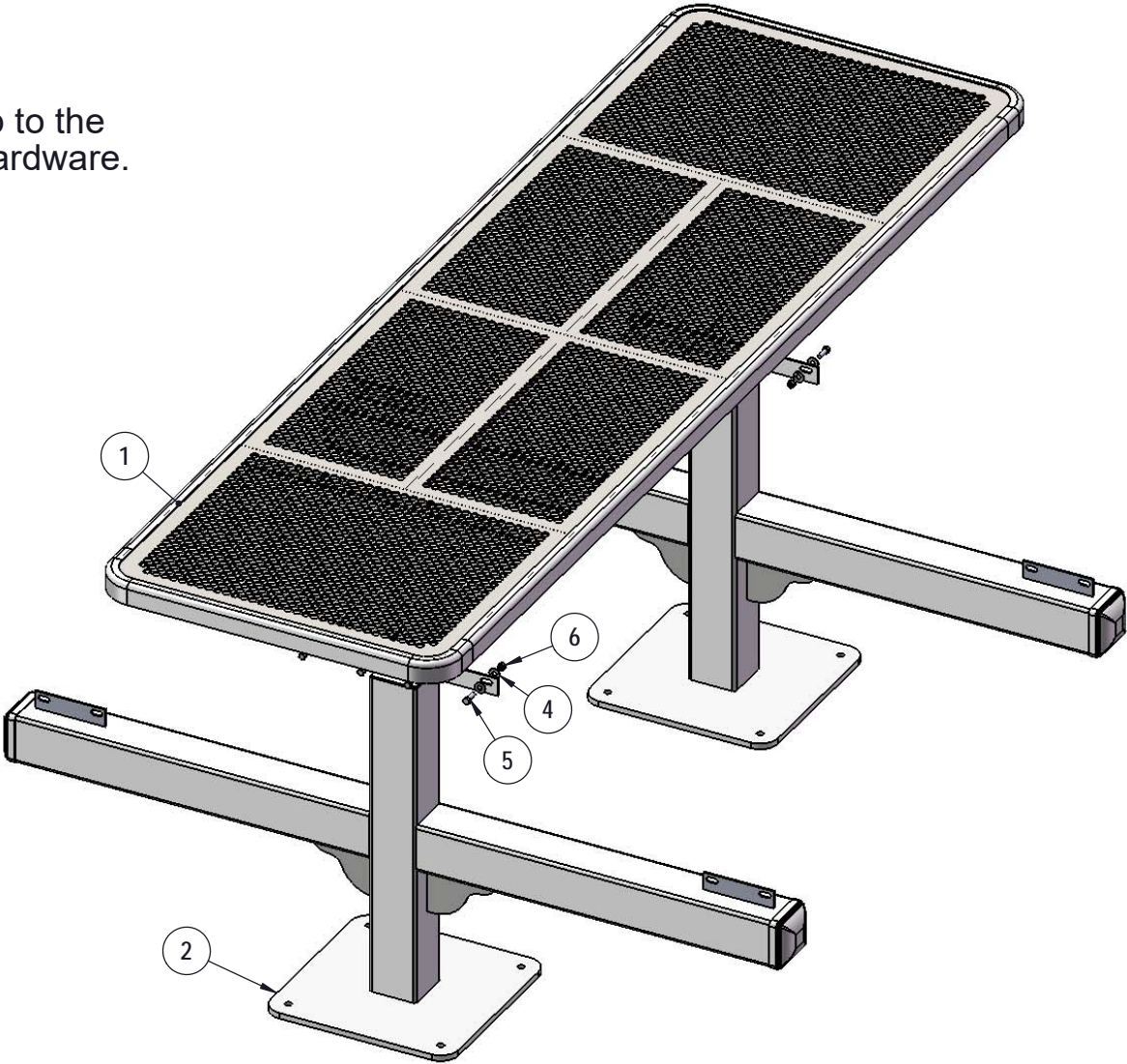

STEP 2

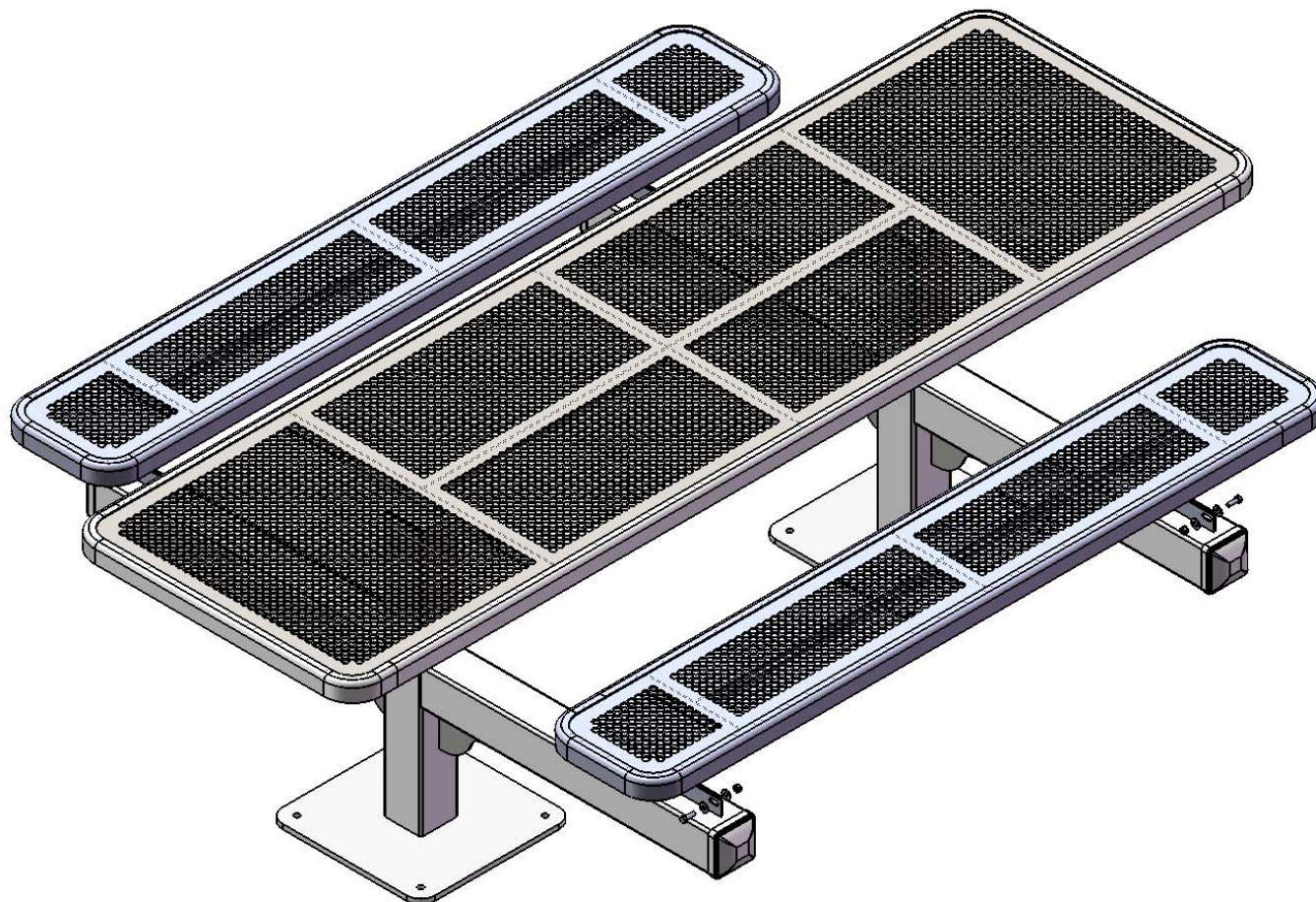

Attach the 6' Benches to the Legs using specified hardware.

OVERALL DIMENSIONS

