

Site Amenities

BY SUPERIOR RECREATIONAL PRODUCTS

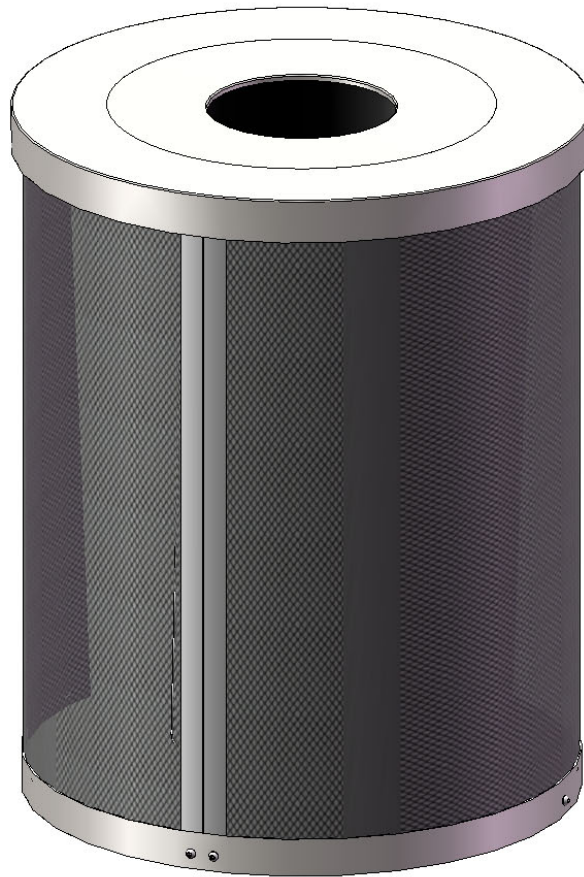

Model # EXE-32FT

SAFETY WARNINGS & EQUIPMENT INSPECTION

- Owners and installers please note these safety warnings and make use of this checklist on a regular basis.
- Follow installation instructions when erecting equipment.
- Ground surfaces around equipment should be restored as needed. Concrete footings should never be exposed. Surface depth should comply with ASTM and CPSC specifications.
- Check for and repair damage caused by wear or vandalism, a major factor in injury causing situations.
- All protruding bolts should be covered or cut off and finished smooth. Sharp edges on pipes should be capped or removed. Check for bent, broken, or severely worn pipe, and replace.
- All equipment should be free of rust and repainted whenever necessary to deter rusting.
- We provide our customers with layout sheets and installation instructions. Please keep on file the specifications sheet that contains the listing of every part used.
- Never add components not intended for use with this product.
- Regular maintenance is necessary in this and all park and recreational equipment to insure the safety of the user.
- Note: Proper maintenance of equipment requires regular tightening of all bolts, nuts, and setscrews.
- Note: Regular checking of all parts, castings, etc. should be made. If a part is broken or worn, it should be replaced immediately.
- Check to be sure all fittings are tight and that bars and pipes do not move.
- Replace all worn S-hooks. S-hooks must be completely closed. Failure to close S-hooks can result in serious injury to the user. NEVER reuse S-hooks.
- Test for free movement of swing hanger and other moving attached parts.
- Check for worn chains and replace them.
- A soft resilient surface should be placed under all swings extending at least twice the height of the top rail both front and back.

TOOLS AND HARDWARE REQUIRED FOR MOUNTING OPTIONS

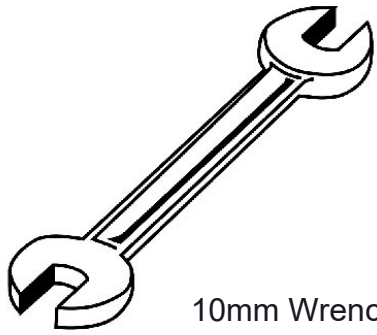

10mm Wrench

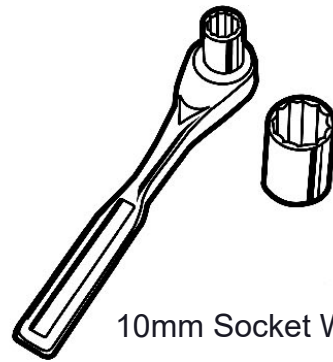

10mm Socket Wrench

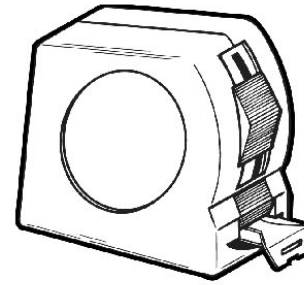

Tape Measure

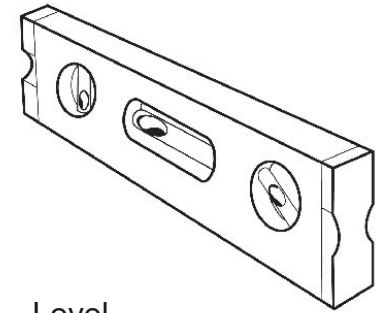

Level

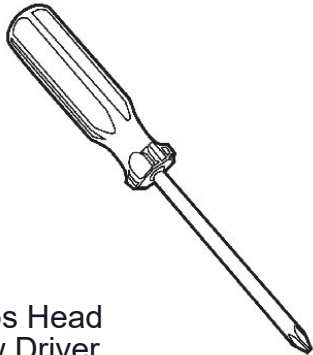

Phillips Head
Screw Driver



M6 x 25mm
Button Head Bolt



M6 x 20mm
Button Head Bolt

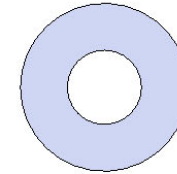

M6 Flat Washer

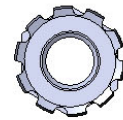

M6 Flange Nut

PRODUCT SPECIFICATIONS

EXE-32FT 32 GALLON BOLT TOGETHER RECEPTACLE WITH FLATTOP & LINER

Receptacle Coating: Oven fused functionalized polyethylene copolymer-based thermoplastic. Fluidized bed coating application with superior mechanical performance, impact resistance and UV-stability.

Material: 3/4" #9 steel expanded metal. 11 gauge x 1-1/2" flat strip border the top and bottom of the expanded metal, and the vertical seam. Bottom plate fabricated from 11 gauge sheet steel laser cut for a precision fit. All electrically MIG welded.

Receptacle Dimensions: 24-1/4" diameter x 30" high x 32 gallon capacity.

Hardware: Attachment hardware and mounting kit not included (7/16" diameter holes provided in receptacle for mounting).

Flat Top: 16ga steel top with thermoplastic coating 24-1/4" diameter. 8" diameter center opening.

Liner: Heavy duty plastic. 19.4" diameter x 28" high x 1/8" thick. 32 gallon capacity.



COMPONENTS

Note:

1. Attach one end of the cable as shown, then attach other end to receptacle lid.
2. Pull cable tight before tightening bolt.

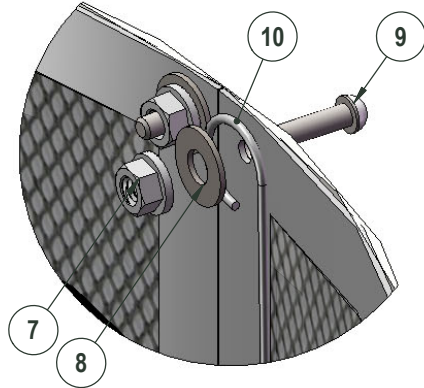

DETAIL A
SCALE 1 : 2

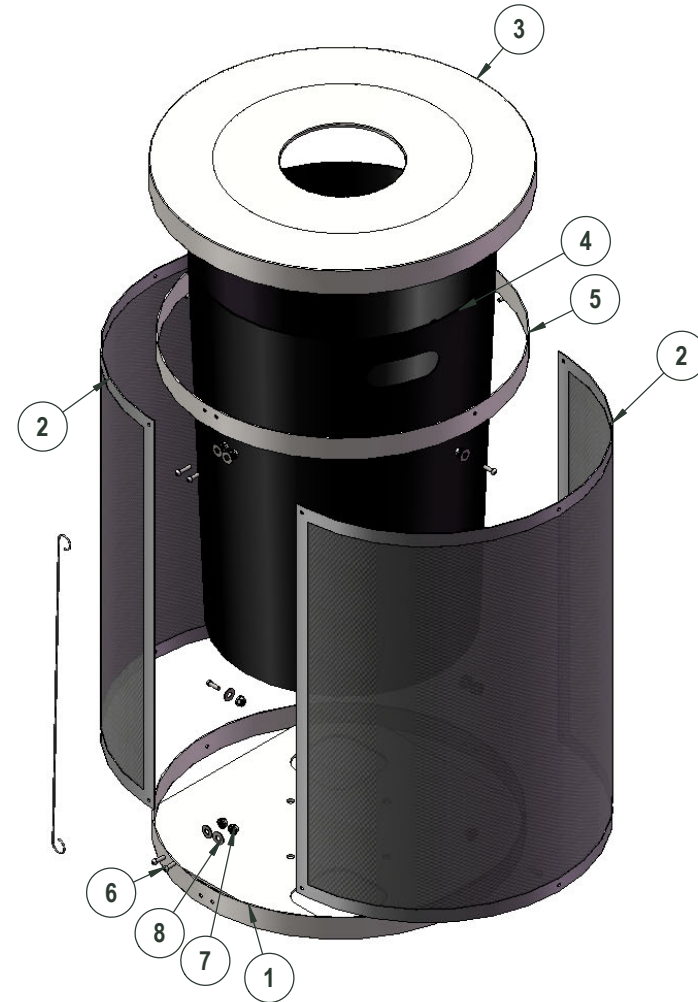

ITEM NO.	PartNo	DESCRIPTION	Qty.
1	T-01-05-0373	32gal bolt together receptacle bottom ring - Thermo	1
2	T-01-05-0371	32gal bolt together receptacle body (half) - Thermo	2
3	T-01-05-0375	32gal bolt together flat lid - Thermo	1
4	PL-32	32 gallon plastic liner	1
5	T-01-05-0374	32gal bolt together receptacle top ring - Thermo	1
6	-	M6 x 20mm Button Head Bolt	11
7	-	M6 Flange Nut	12
8	-	M6 Flat Washer	12
9	-	M6 x 25mm Button Head Bolt	1
10	-	1/8" x 23-1/2" long Cable	1