

1

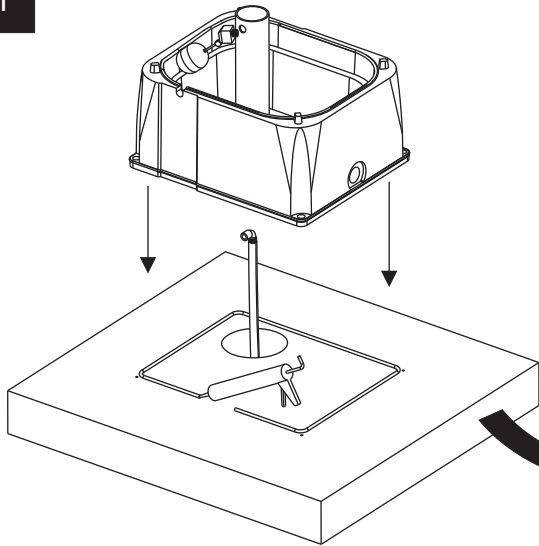

2

LENGTH 28"  
WIDTH 23"  
HEIGHT 20"

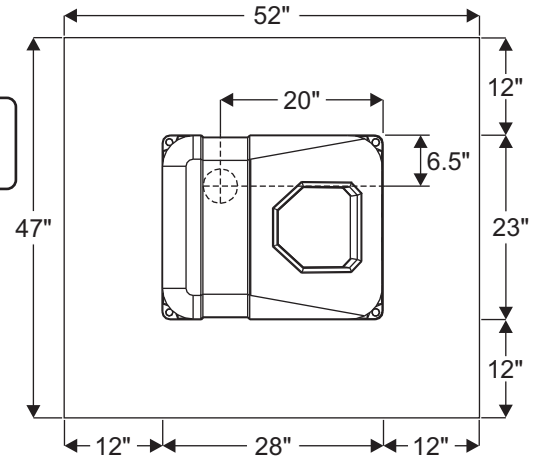

3

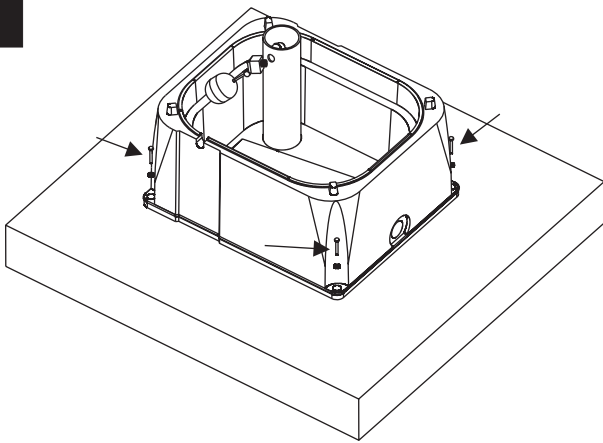

4

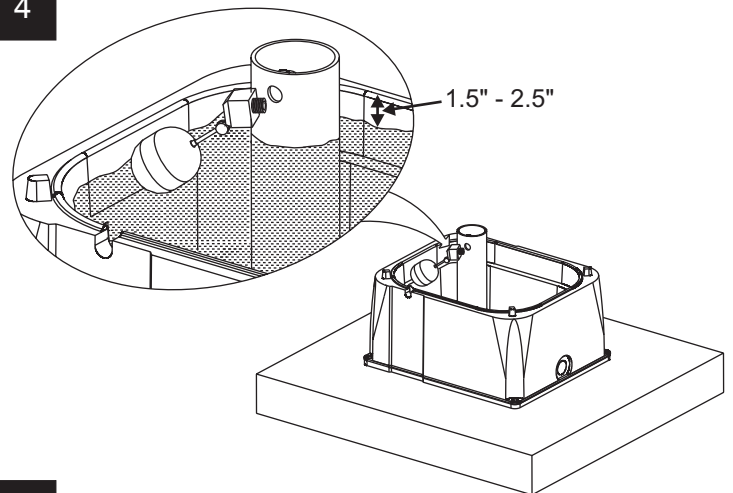

5

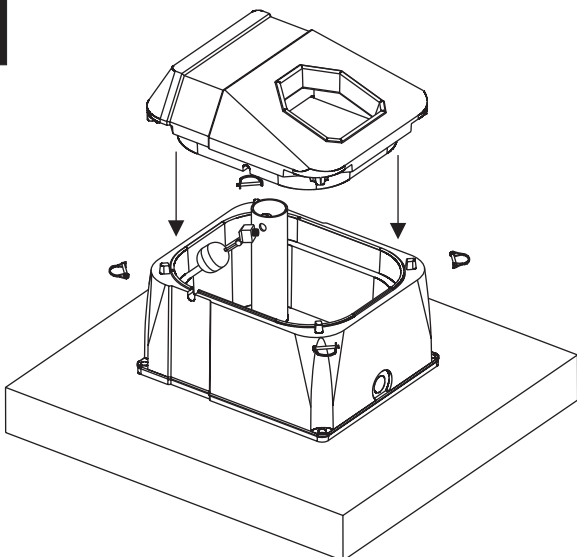

6

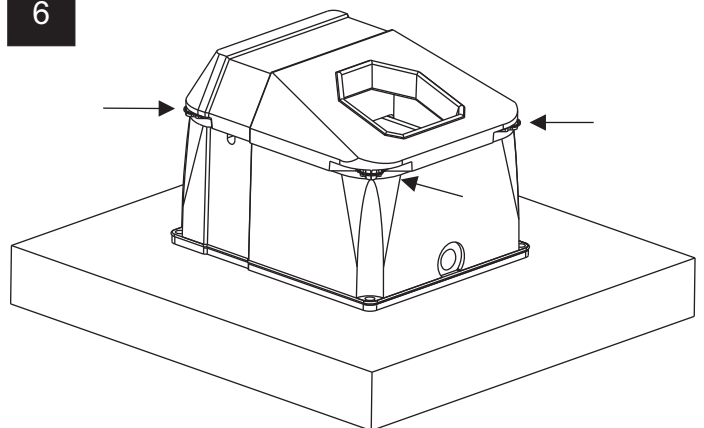

7

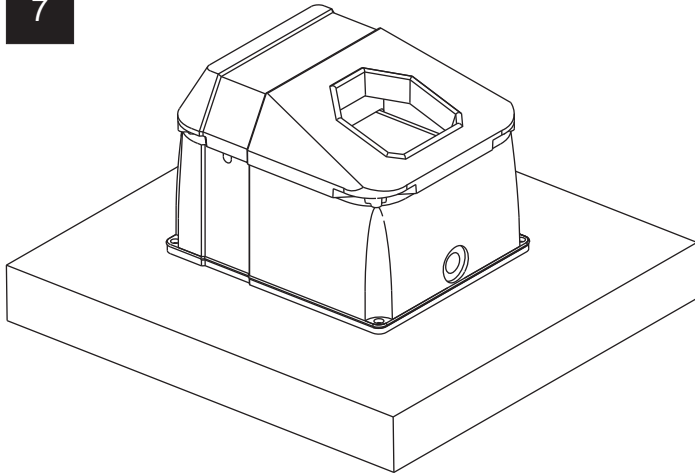

Copyright © 2023

8

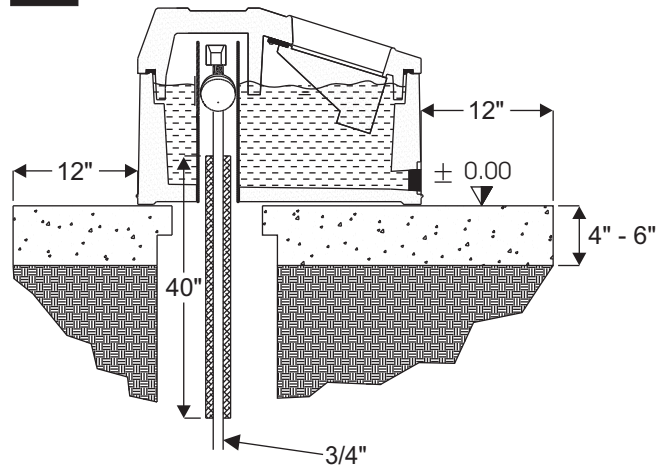

**Water Pressure:** Please note the valve is appropriate for water pressure up to 55 psi.

Updated: February 2023

It is our goal to provide our customers with the finest in livestock watering equipment products.

There is a 10 (ten) year warranty on any purchase of our livestock watering equipment, which includes the models listed below. This warranty covers defects in the material or workmanship. The warranty however, is limited only to the value of the defected part and does not include any freight charges, loss of production and/or changes in operation. It does not cover damage due to careless machine handling and neglect. Proof of purchase is required.

<b>Electric Models**:</b>	EE10NG, VS15E, VS20E, VS20LPE
<b>Energy Free Models:</b>	351NG, 352NG, 354NG
<b>Tip Tanks:</b>	TIPTANK4,NG, TIPTANK7,NG
<b>XL Series:</b>	7XL, 10XL, 12XL
<b>Stock Tanks:</b>	42GALLON, 120GALLON, 180GALLON
<b>Value Series:</b>	VS15, VS20, VS20LP

**1 (One) Year Warranty for:**

- Float and Valve
- Door Hinges
- Submersible Heater and Heat Tape

**Water Pressure:** The valve is appropriate for water pressure up to 55 psi.

**\*\*Note:** To ensure the life of your electric livestock waterer be sure that the waterer is drained and shut off when not in use.

Copyright © 2023

Updated: February 2023